



SUZUKI **FX125**

PARTS CATALOGUE

1998



16 JAN 1999

INFORMATION
ILLUSTRATION INDEX **1**

ENGINE
TRANSMISSION **2**

ELECTRICAL **3**

BODY **4**

PARTS NUMBER INDEX **5**

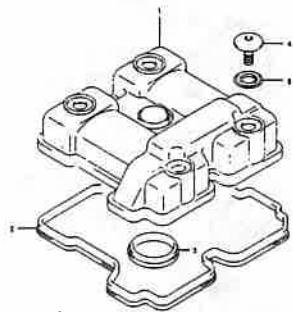
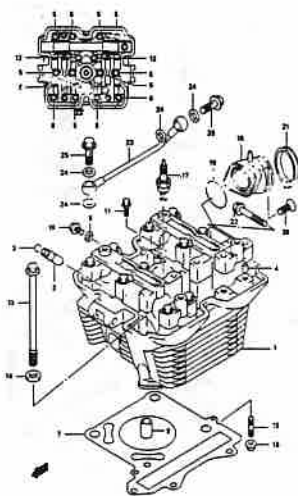
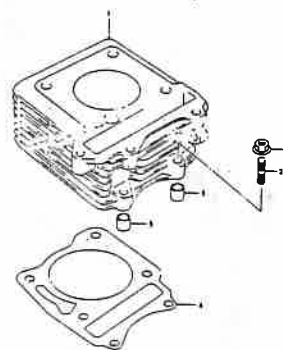
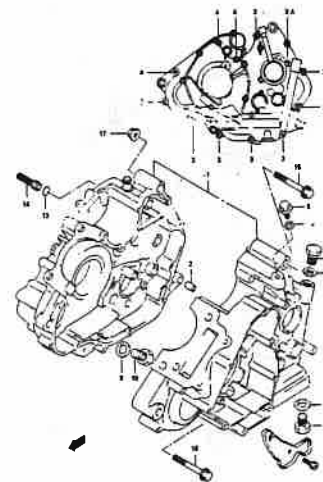
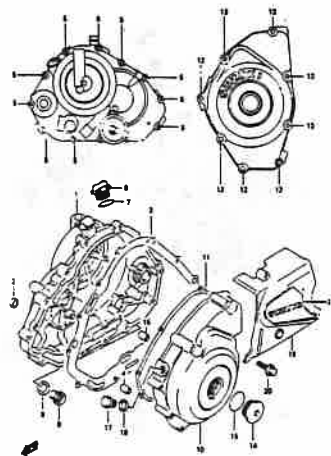
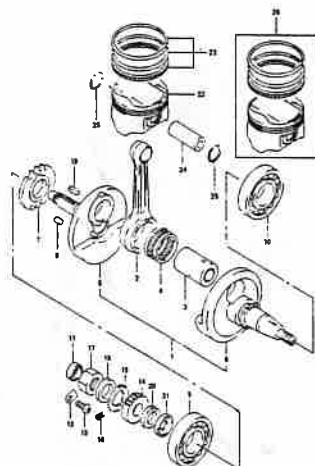
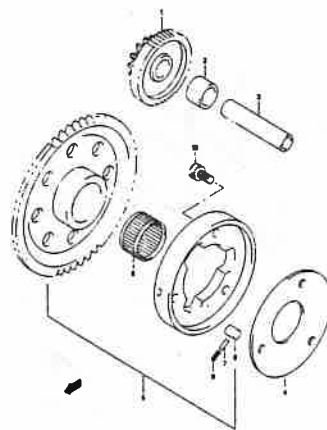
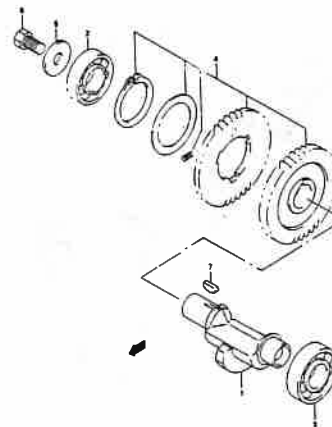
FIG. 1**FIG. 2****FIG. 3****FIG. 4****FIG. 5****FIG. 6****FIG. 7****FIG. 8**

FIG. 9

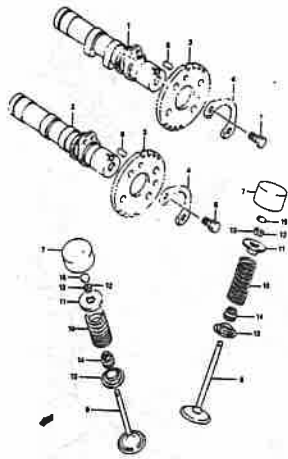


FIG. 10

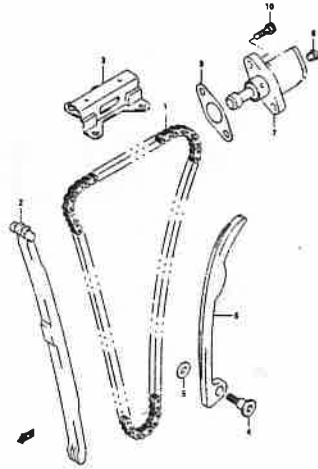


FIG. 11

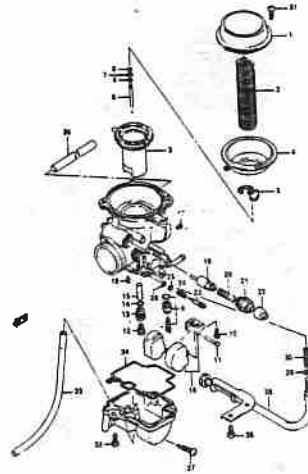


FIG. 12

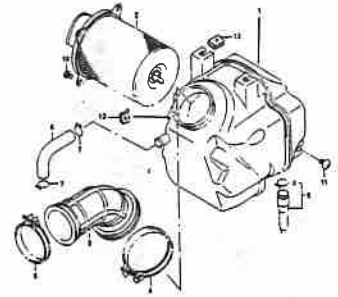


FIG. 13

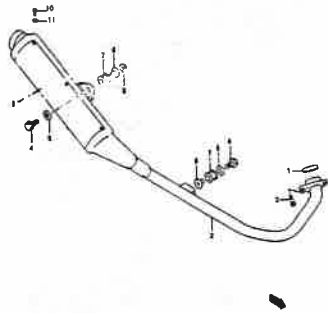


FIG. 14

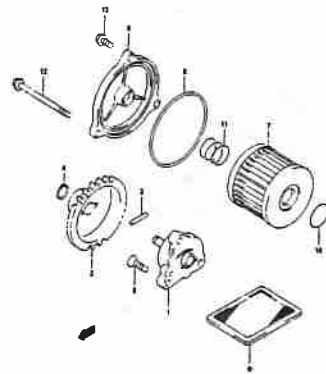


FIG. 15

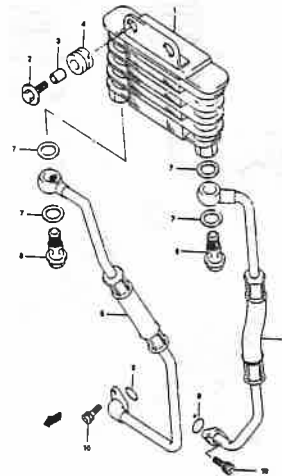


FIG. 16

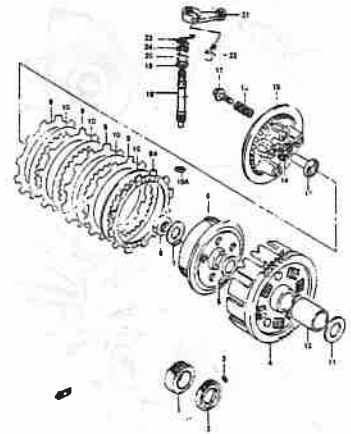


FIG. 17

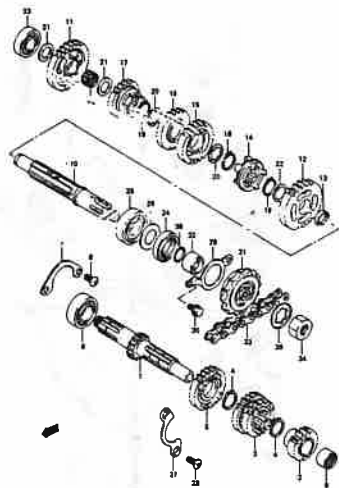


FIG. 18

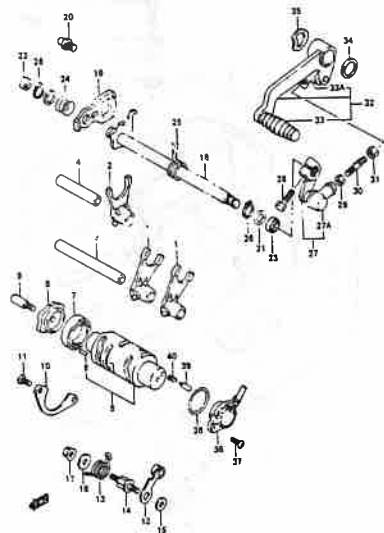


FIG. 19

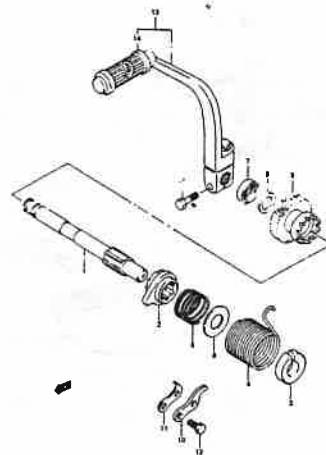


FIG. 20

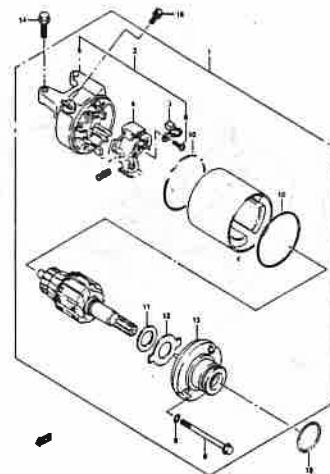


FIG. 21

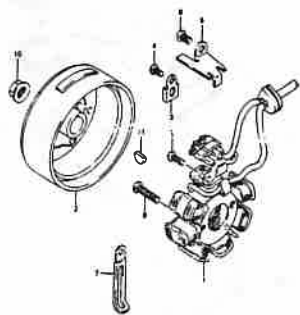


FIG. 22

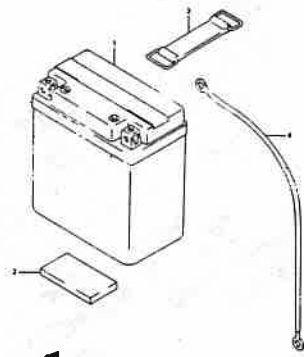


FIG. 23

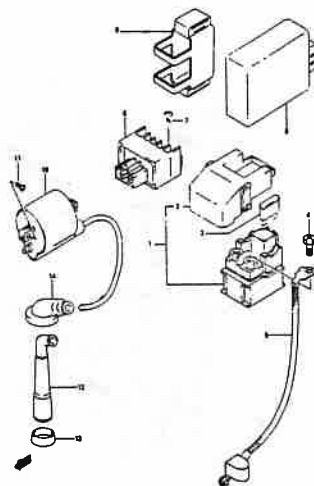


FIG. 24

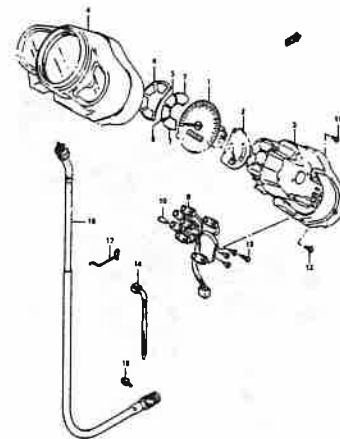


FIG. 25

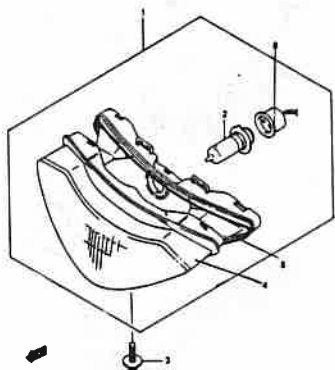


FIG. 26

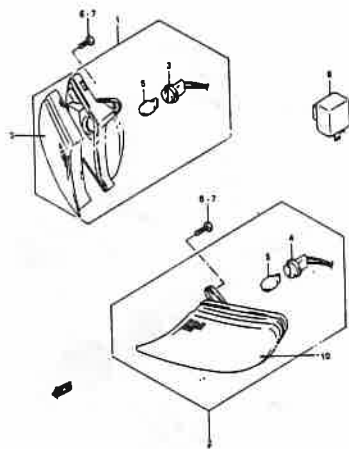


FIG. 27

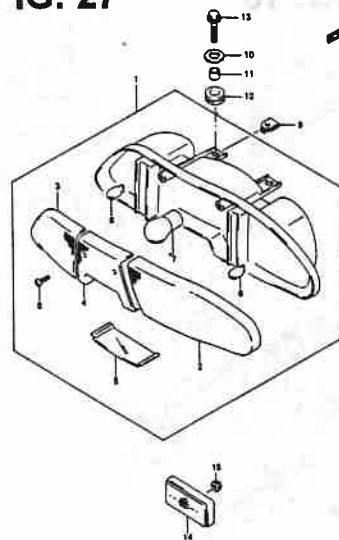


FIG. 28

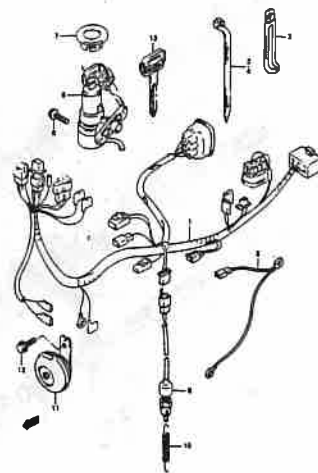


FIG. 29

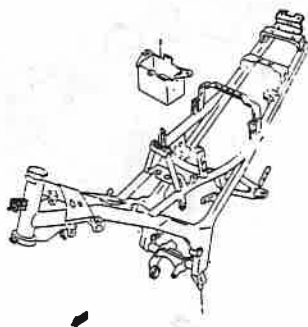


FIG. 30

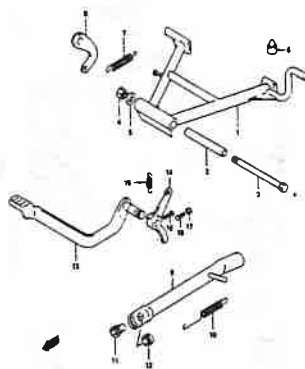


FIG. 31

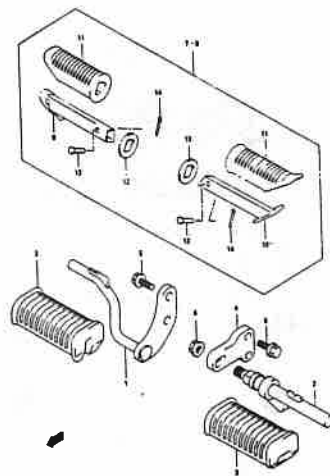


FIG. 32

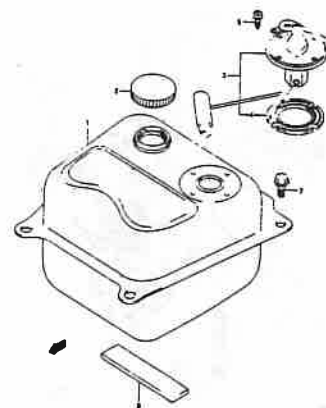


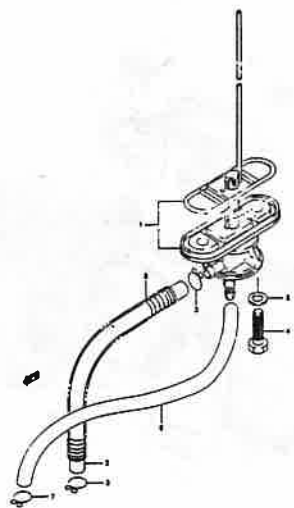
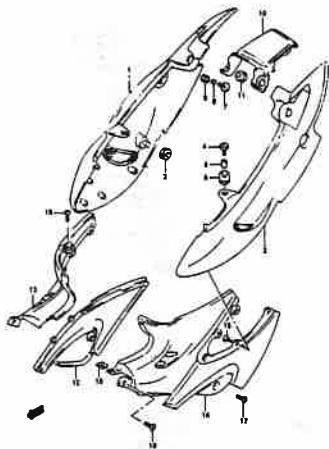
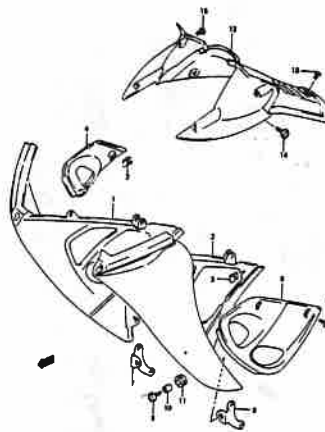
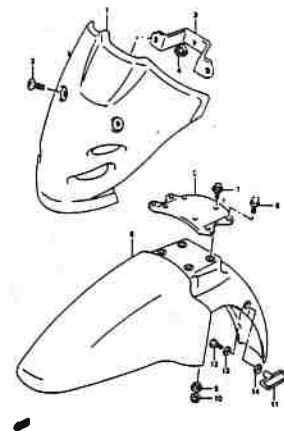
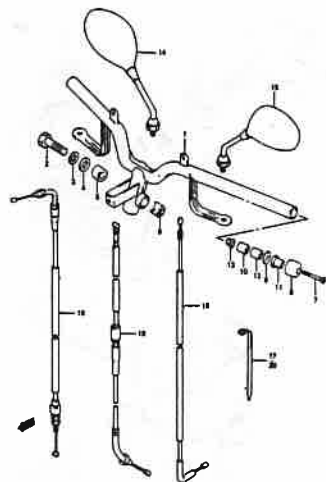
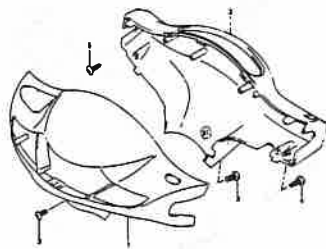
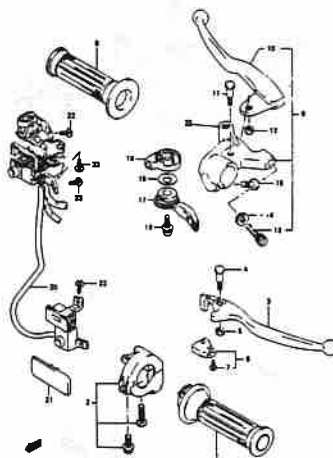
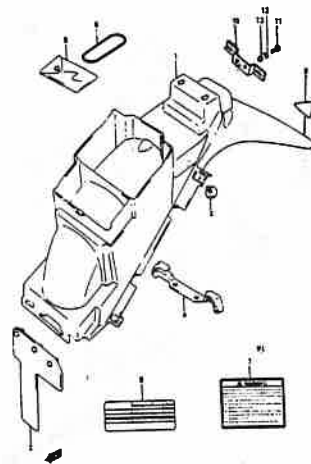
FIG. 33**FIG. 34****FIG. 35****FIG. 36****FIG. 37****FIG. 38****FIG. 39****FIG. 40**

FIG. 41

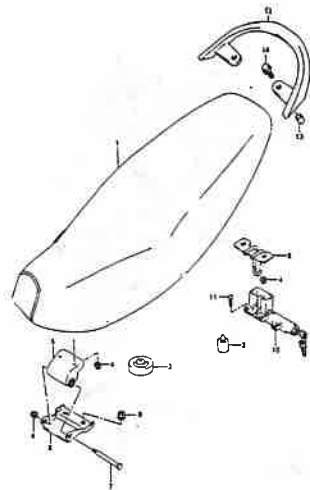


FIG. 42

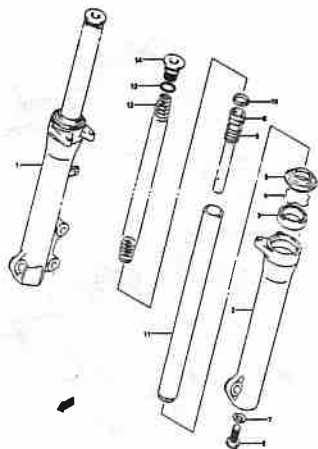


FIG. 43

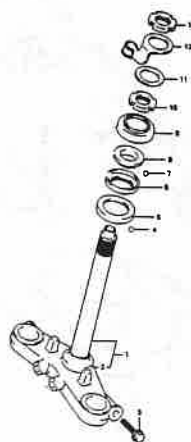


FIG. 44

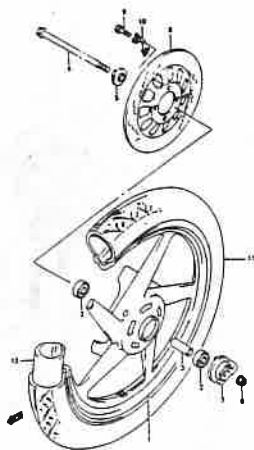


FIG. 45

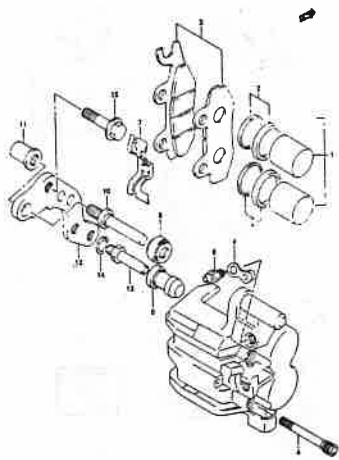


FIG. 46

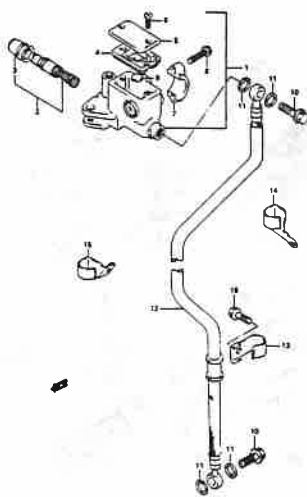


FIG. 47

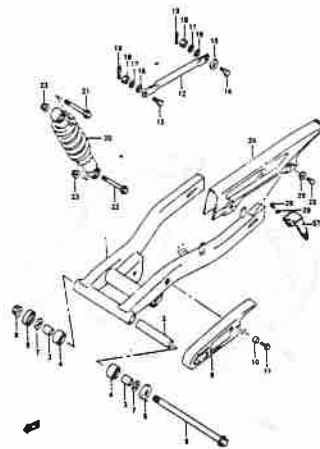


FIG. 48

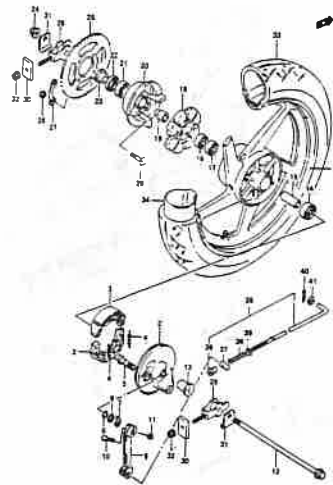


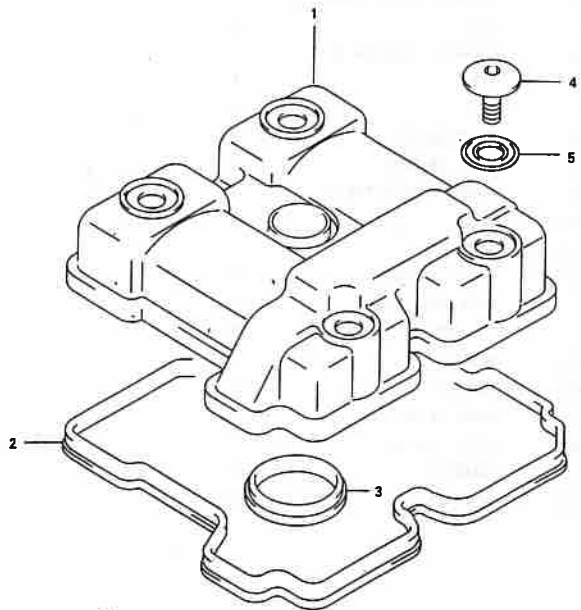
FIG. 49



FIG. 1

FIG. 1 (B-2) CYLINDER HEAD COVER

REF. NO.	PART NO.	DESCRIPTION	QTY	REMARKS
1	11171M47E00	COVER, cylinder head	1	
2	11173-35C00	GASKET, cylinder head cover	1	
3	11178-17E00	GASKET	1	
4	09106-07009	BOLT (7x17.5)	4	
5	09161-11008	WASHER (10.6x25.5x1.6)	4	



2

FIG. 2

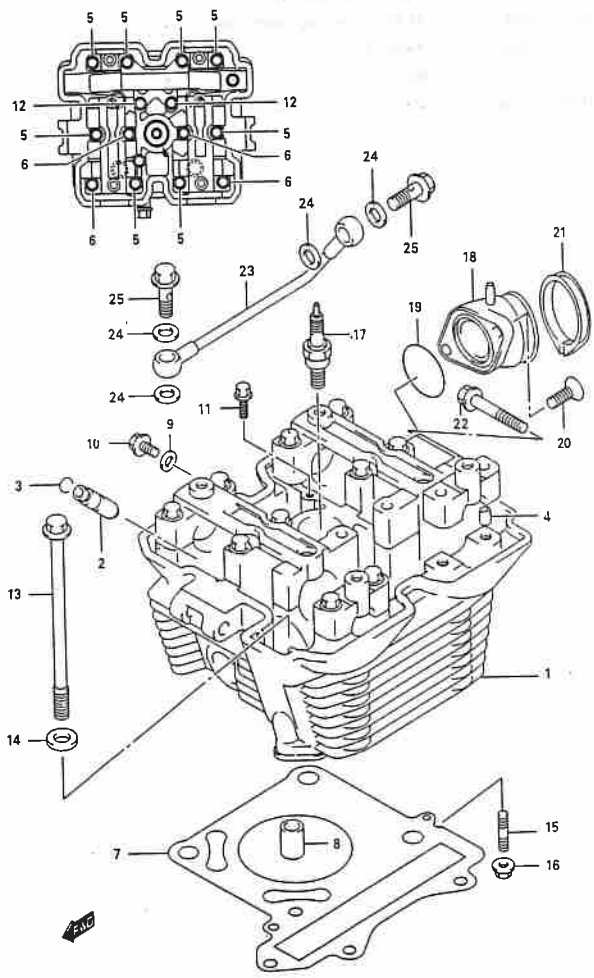
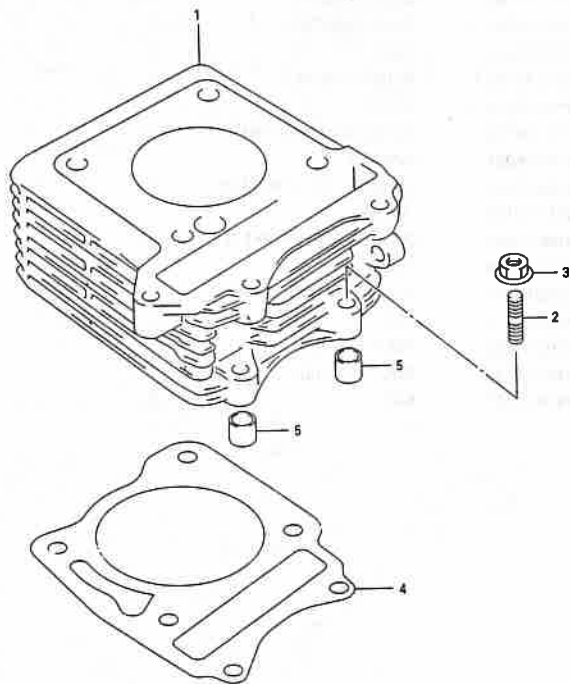


FIG. 2 (B-3) CYLINDER HEAD

REF. NO.	PART NO.	DESCRIPTION	QTY	REMARKS
1	11100M47E00	HEAD ASSY, cylinder	1	
2	11115-33D71	.GUIDE, valve	4	
3	09381-10004	.SNAP RING	4	
4	09206-08001	.PIN (6.2x8x11)	8	
5	09103-06132	.BOLT (6x41)	8	
6	09103-06108	.BOLT (6x35)	4	
7	11141-47E00	GASKET, cylinder head	1	
8	04211-11169	PIN	2	
9	09168-06004	GASKET (6.2x11x1.2)	1	
10	01550-06123	BOLT	1	
11	01550-06123	BOLT	1	
12	09103-06108	BOLT (6x35)	2	
13	09103-08305	BOLT (8x140)	4	
14	09168-08021	GASKET (8.5x17x2.3)	4	
15	01421-06253	BOLT	3	
16	08316-10063	NUT	3	
17	09482M00456	SPARK PLUG	1	
18	13110-47E00	PIPE ASSY, intake	1	
19	09280-35001	.O RING (D:1.9, ID: 34.6)	1	
20	02112-06163	SCREW	2	
21	09402-46208	CLAMP	1	
22	09103-08289	BOLT (8x50)	1	
23	11280-47E00	PIPE, head oil	1	
24	09168-10012	GASKET	4	
25	09360-10047	UNION BOLT	2	

FIG. 3**FIG. 3 (B-4) CYLINDER**

REF. NO.	PART NO.	DESCRIPTION	QTY	REMARKS
1	11210M47E00-0F0	CYLINDER	1	
2	01421-06253	STUD BOLT	2	
3	08316-10063	NUT	2	
4	11241M35C00	GASKET, cylinder	1	
5	04211-11129	PIN	2	

2

FIG. 4

2

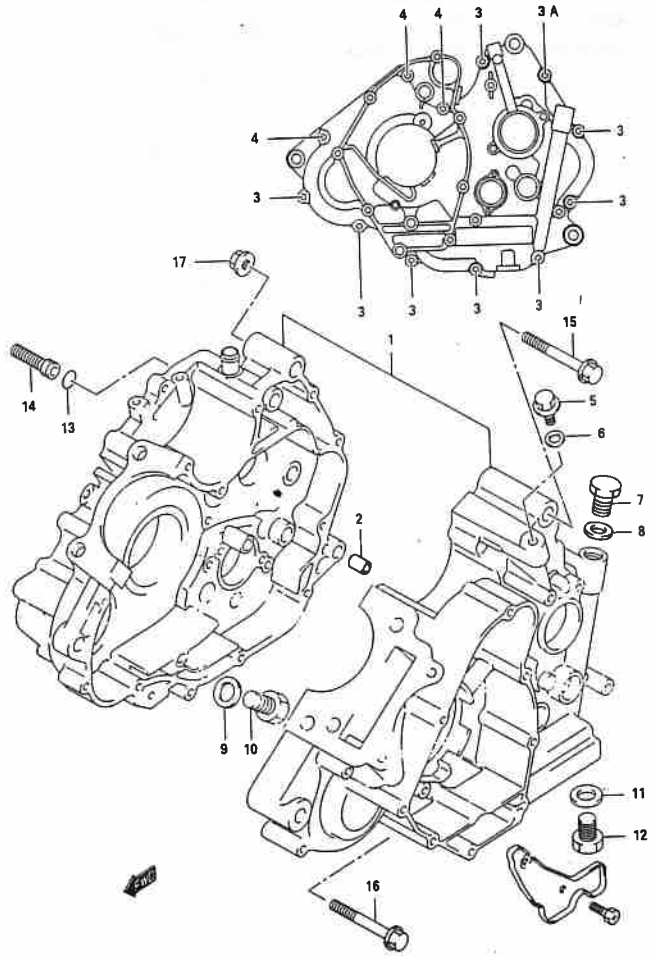


FIG. 4 (B-5) CRANKCASE

REF. NO.	PART NO.	DESCRIPTION	Q'TY	REMARKS
1	11300M05F10	CRANKCASE ASSY	1	
1-1	11310M05F10	CRANKCASE RH	1	
1-2	11320M05F10	CRANKCASE LH	1	
2	04211-13189	.PIN	2	
3	01547-06403	.BOLT (GREEN)	8	
3A	01547-06407	.BOLT (CHROME)	1	
4	01547-06653	.BOLT	3	
5	09247-12103	.PLUG, breather	1	
6	09168-12002	.GASKET	1	
7	01550-06123	.PLUG, oil gallery mission	1	
8	09168-06004	.GASKET	1	
9	09168-12002	.GASKET (12.1x16.2x1.2)	1	
10	09247-12103	..PLUG	1	
11	09168-12002	GASKET (12.1x16.2x3.7)	1	
12	09247-12106	PLUG	1	
13	09280-04004	O RING (D:1.2, ID: 4.0)	1	
14	09493-24012	JET	1	
15	09103-10052	BOLT (10x120)	1	
16	09103-10148	BOLT (10x110)	1	
17	08319-31107	NUT	2	

FIG. 5

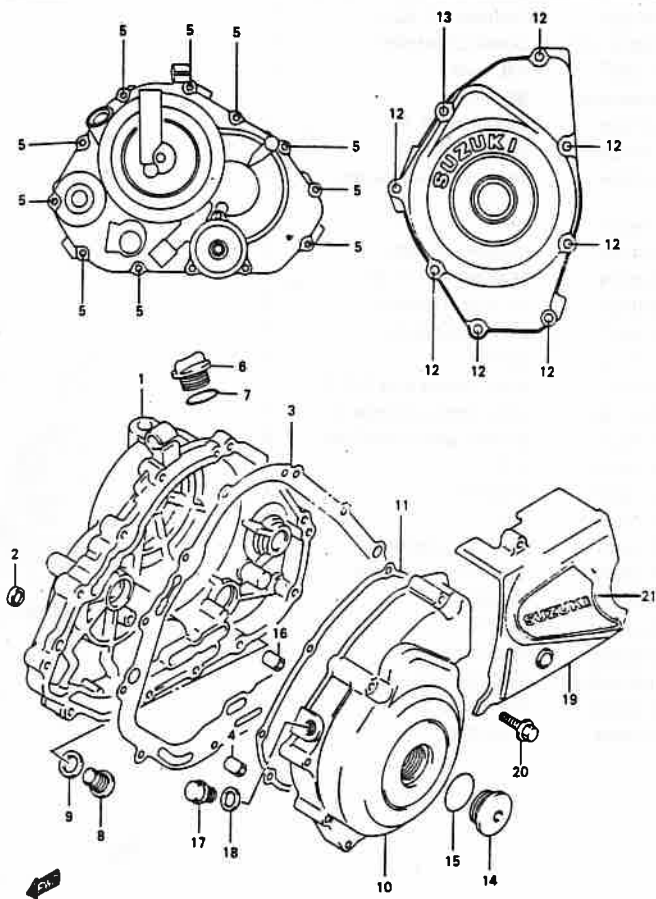


FIG. 5 (B-6) CRANKCASE COVER

REF. NO.	PART NO.	DESCRIPTION	Q'TY	REMARKS
1	11340M47E00	COVER, clutch	1	
2	11971-45010	.LENS, oil level cover	1	
3	11482M47E00	GASKET, clutch cover	1	
4	04211-09149	PIN	2	
5	01547-06303	BOLT	10	
6	09259-20008	PLUG (20x10)	1	
7	09280-17003	O RING (D: 3.1, ID: 16.8)	1	
8	09248-14005	PLUG	1	
9	09168-14002	GASKET (13.8x18.8x0.4)	1	
10	11351M47E00	COVER, magneto	1	
11	11483M47E00	GASKET, magneto cover	1	
12	01547-06353	BOLT	7	
13	01547-06503	BOLT	1	
14	09259-26011	PLUG	1	
15	09280-22008	O RING (D: 3.1, ID: 22.7)	1	
16	04211-09149	PIN	1	
17	09247-14026	PLUG	1	
18	09168-14002	GASKET (13.8x18.8x0.4)	1	
19	11361M47E00	COVER, engine sprocket	1	
20	01547-06253	BOLT	3	
21	11369M47E00	DAMPER, cover eng. sprocket	1	

2

FIG. 6

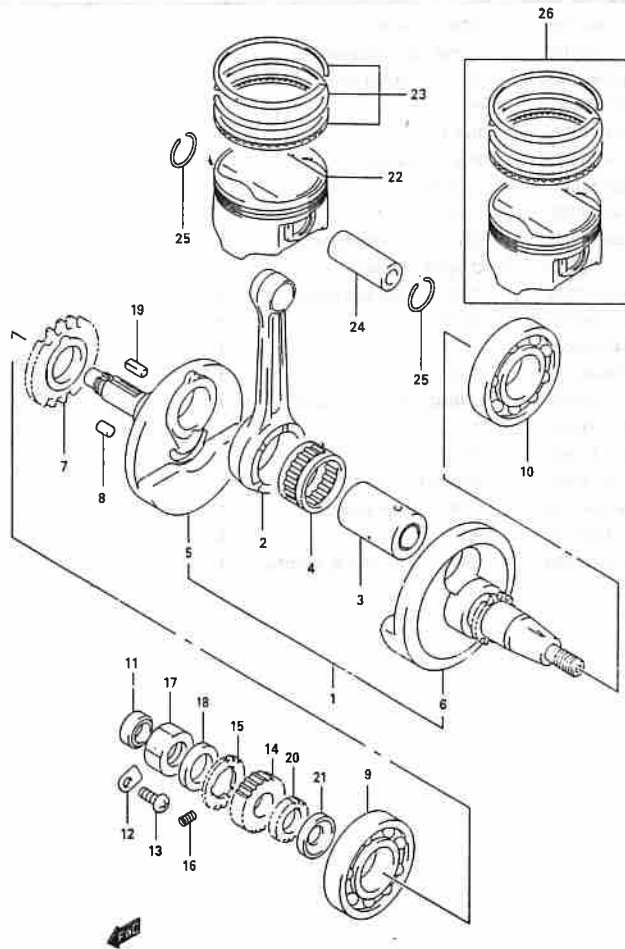


FIG. 6 (B-7) CRANKSHAFT

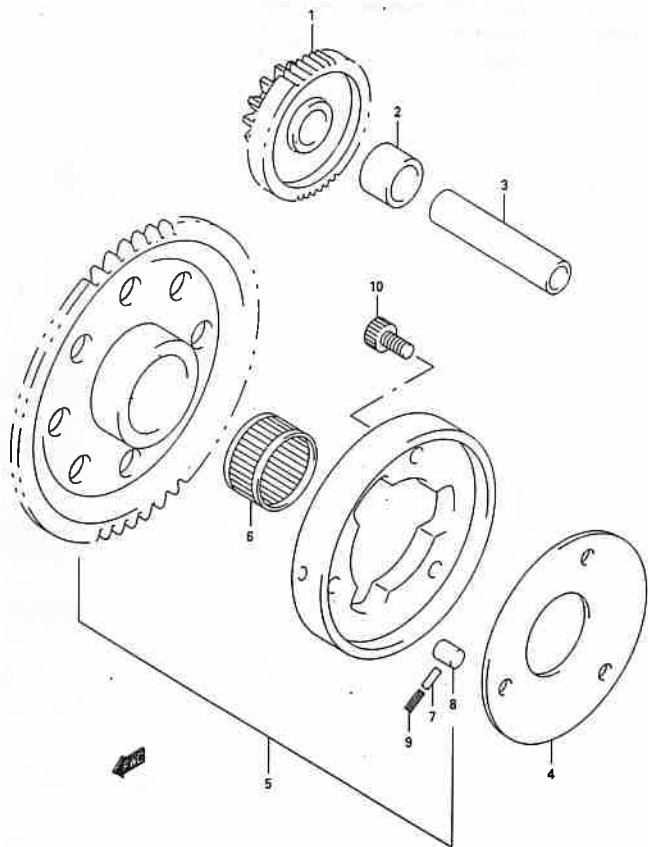
REF. NO.	PART NO.	DESCRIPTION	QTY	REMARKS
1	12200-47E00	CRANKSHAFT ASSY	1	
2	12161-35C01-0B0	.CONNECTION ROD	1	
3	12211-47E00	.PIN, crank	1	
4	09263-28032-0B0	.BEARING	1	
5	12220-47E00	.CRANKSHAFT, RH	1	
6	12261-47E00	.CRANKSHAFT, LH	1	
7	12661-47E00	GEAR, crank balancer drive (NT: 37)	1	
8	04221-08129	PIN	1	
9	09262-28035	BEARING (28x68x17)	1	RH
10	09262-35038	BEARING (35x72x17)	1	LH
11	09282-12009	OIL SEAL (12x21x7)	1	
12	24742-18A00	RETAINER, bearing	1	
13	02112-06123	SCREW	1	
14	21111-35C20	GEAR, primary drive (NT: 21)	1	
15	21112-35C00	GEAR, primary drive no. 2	1	
16	21114-35C00	SPRING, primary drive gear	3	
17	09140-16019	NUT	1	
18	09166-16012	WASHER	1	
19	09421-04004	KEY	1	
20	16321-05201	GEAR, oil pump drive	1	
21	16311-47E00	SPACER, oil pump gear	1	
22	12111M47E00-0F0	PISTON	1	
22-1	12111M47E00-050	PISTON	1	
23	12140-20E50	RING SET, piston	1	
23-1	12140M20E50-050	RING SET, piston	1	
24	12151-30B00	PIN, piston	1	
25	09381-15001	SNAP RING	2	

2

FIG. 7

FIG. 7 (B-8) STARTER CLUTCH

REF. NO.	PART NO.	DESCRIPTION	Q'TY	REMARKS
1	12611-47E00	GEAR, starter idle no. 1 (NT: 15/53)	1	
2	09180-13007	SPACER	1	
3	09206-13003	PIN (13x7.4x56)	1	
4	12649-30D00	SHIM, starter clutch hub	1	
5	12600-47831	CLUTCH SET, starter	1	
6	09263-22031	.BEARING (22x28x16)	1	
7	12633-05300	.PIECE	3	
8	09261-10003	.ROLLER	3	
9	09440-03004	.SPRING	3	
10	07130-06123	BOLT	3	



2

FIG. 8

2

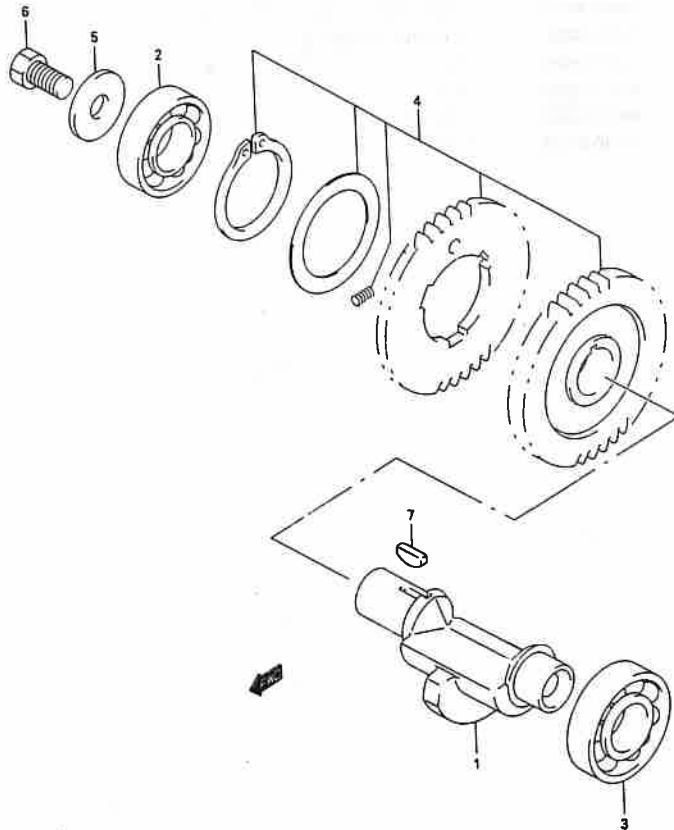


FIG. 8 (B-9) CRANK BALANCER

REF. NO.	PART NO.	DESCRIPTION	Q'TY	REMARKS
1	12651-47E00	BALANCER, crank	1	
2	09262-20137	BEARING (20x42x12)	1	RH
3	09262-20019	BEARING (20x47x14)	1	LH
4	12660-47810	GEAR SET, crank balancer driven	1	
5	08211-10285	WASHER	1	
6	01550-10163	BOLT	1	
7	09420-04008	KEY	1	

FIG. 9

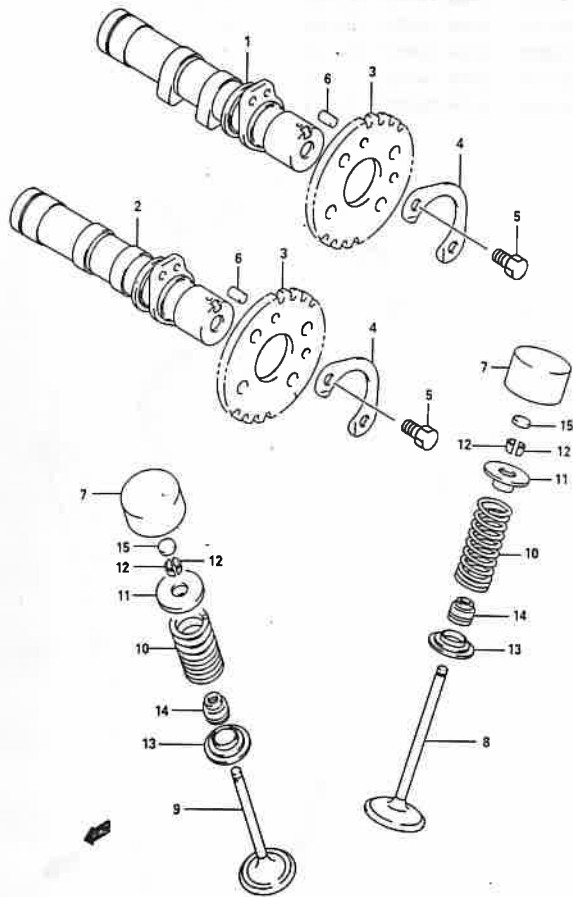


FIG. 9 (B-10) CAM SHAFT / VALVE

REF. NO.	PART NO.	DESCRIPTION	Q'TY	REMARKS
1	12710-47E00	CAM SHAFT, intake	1	
2	12720-47E10	CAM SHAFT, exhaust	1	
3	12741-16E00	SPROCKET, camshaft	2	
4	12747-44B00	WASHER	2	
5	09111-06032	BOLT	4	
6	09261-05005	PIN	2	
7	12891-16E00	TAPPET	4	
8	12911-16E00	VALVE, intake	2	
9	12912-16E00	VALVE, exhaust	2	
10	12921-47E00	SPRING, valve	4	
11	12931-16E00	RETAINER, valve spring	4	
12	12932-32C00	COTTER, valve	8	
13	12933-16E00	SEAT, valve spring	4	
14	09289-04002	OIL SEAL (4.5x10x8)	4	
15-1	12892-05C00-120	SHIM, TAPPET (T: 1.20)	4	
15-2	12892-05C00-125	SHIM, TAPPET (T: 1.25)	4	
15-3	12892-05C00-130	SHIM, TAPPET (T: 1.30)	4	
15-4	12892-05C00-135	SHIM, TAPPET (T: 1.35)	4	
15-5	12892-05C00-140	SHIM, TAPPET (T: 1.40)	4	
15-6	12892-05C00-145	SHIM, TAPPET (T: 1.45)	4	
15-7	12892-05C00-150	SHIM, TAPPET (T: 1.50)	4	
15-8	12892-05C00-155	SHIM, TAPPET (T: 1.55)	4	
15-9	12892-05C00-160	SHIM, TAPPET (T: 1.60)	4	
15-10	12892-05C00-165	SHIM, TAPPET (T: 1.65)	4	
15-11	12892-05C00-170	SHIM, TAPPET (T: 1.70)	4	
15-12	12892-05C00-175	SHIM, TAPPET (T: 1.75)	4	
15-13	12892-05C00-180	SHIM, TAPPET (T: 1.80)	4	
15-14	12892-05C00-185	SHIM, TAPPET (T: 1.85)	4	
15-15	12892-05C00-190	SHIM, TAPPET (T: 1.90)	4	

2

FIG. 9

2

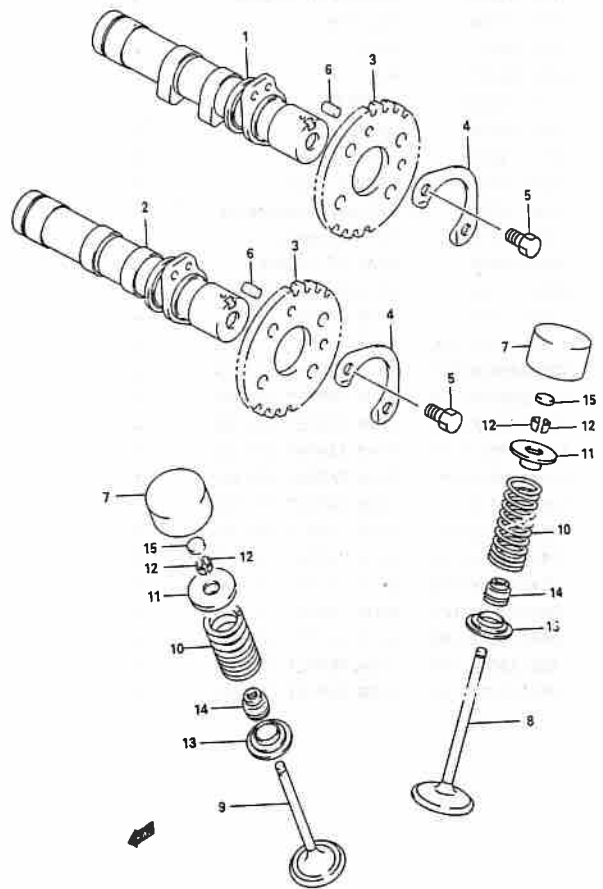


FIG. 9 (B-11) CAM SHAFT / VALVE

REF. NO.	PART NO.	DESCRIPTION	QTY	REMARKS
15-16	12892-05C00-195	SHIM, TAPPET (T: 1.95)	4	
15-17	12892-05C00-200	SHIM, TAPPET (T: 2.00)	4	
15-18	12892-05C00-205	SHIM, TAPPET (T: 2.05)	4	
15-19	12892-05C00-210	SHIM, TAPPET (T: 2.10)	4	
15-20	12892-05C00-215	SHIM, TAPPET (T: 2.15)	4	
15-21	12892-05C00-220	SHIM, TAPPET (T: 2.20)	4	

FIG. 10

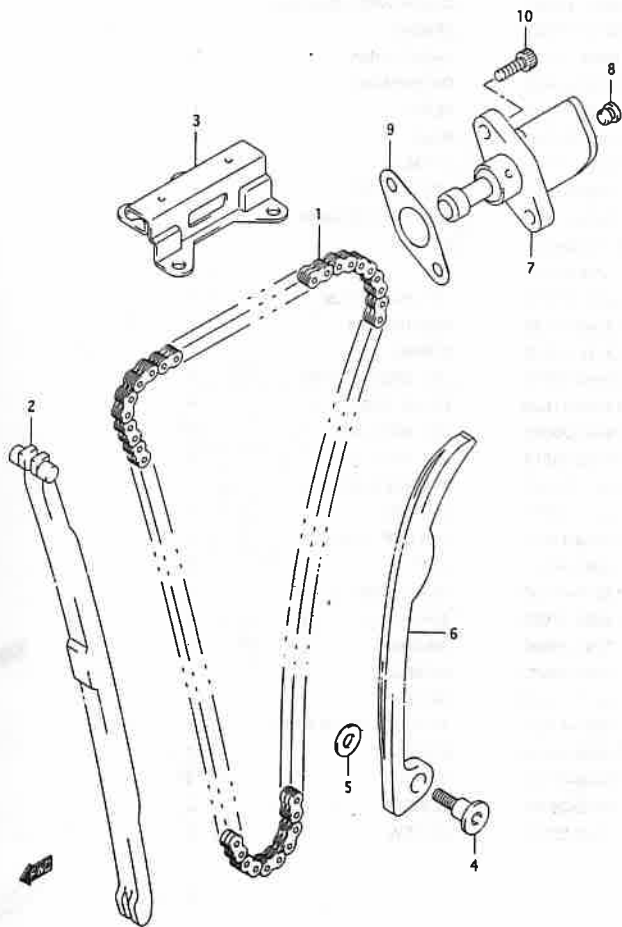


FIG. 10 (B-12) CAM CHAIN

REF. NO.	PART NO.	DESCRIPTION	Q'TY	REMARKS
1	12760-16E00	CHAIN, cam shaft drive	1	
2	12771-16E00	GUIDE, cam chain no. 1	1	
3	12782-47E00	GUIDE, cam chain no. 2	1	
4	12812-35C00	BOLT, cam chain tensioner	1	
5	08211-06181	WASHER	1	
6	12811-16E00	TENSIONER, cam chain	1	
7	12830-31312	ADJUSTER ASSY, tensioner	1	
8	12839-38200	PLUG, adjuster	1	
9	12837M31320	GASKET, tensioner adjuster	1	
10	07130-06203	BOLT	2	

2

FIG. 11

FIG. 11 (C-2) CARBURETOR

REF. NO.	PART NO.	DESCRIPTION	Q'TY	REMARKS
	13200-47E10	CARBURETOR ASSY	1	
1	13502-47E00	.COVER ASSY, diaphragm	1	
2	13417-47E00	.SPRING	1	
3	13500-47E00	.VALVE, piston	1	
4	13507-04F00	.DIAPHRAGM	1	
5	13581-47E00	.PLATE	1	
6	13387-33E00	.RING	2	
7	13394-17E60	.E RING	1	
8	13383-47E10	.NEEDLE, JET	1	
9	13370-47E00	.VALVE ASSY, needle	1	
10	02112-04083	.SCREW	1	
11	13254-20010	.PIN	1	
12	09491-21019	.JET, main (107.5)	1	
13	13385-05F00	.HOLDER, JET	1	
14	13246-43010	.O RING	1	
15	09494-00907	.JET, NEEDLE (P-0)	1	
16	13240-47E00	.FLOAT ASSY	1	
17	09493-29002	.JET, AIR (1.45)	1	
18	09492-15016	.JET, PILOT (15)	1	
19	13411-01400	.PLUNGER ASSY	1	
20	13417-01010	.SPRING	1	
21	13418-43410	.HOLDER, guide	1	
22	13681-04010	.CAP	1	
23	13279-45400	.SCREW, pilot (1 1/4)	1	
24	13268-47070	.SPRING	1	
25	13291-29900	.WASHER	1	
26	13295-29900	.O RING	1	
27	13247-13A00	.SCREW	1	
28	13267-47E00	.ADJUST SCREW ASSY	1	
29	13615-43010	.PACKING	1	
30	13268-37420	.SPRING	1	
31	02112-05087	.SCREW	2	
32	13601-05148	.SCREW	2	

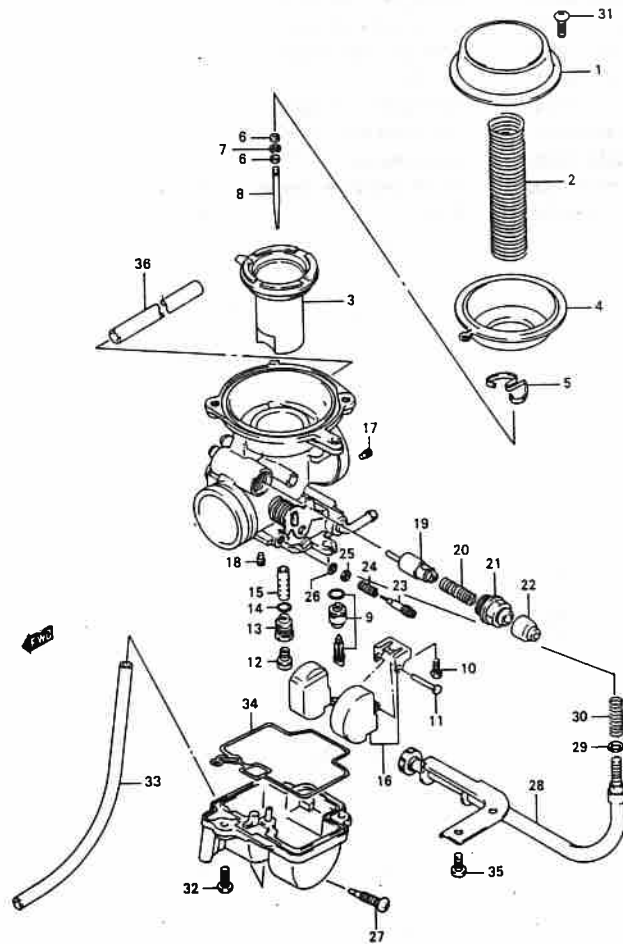
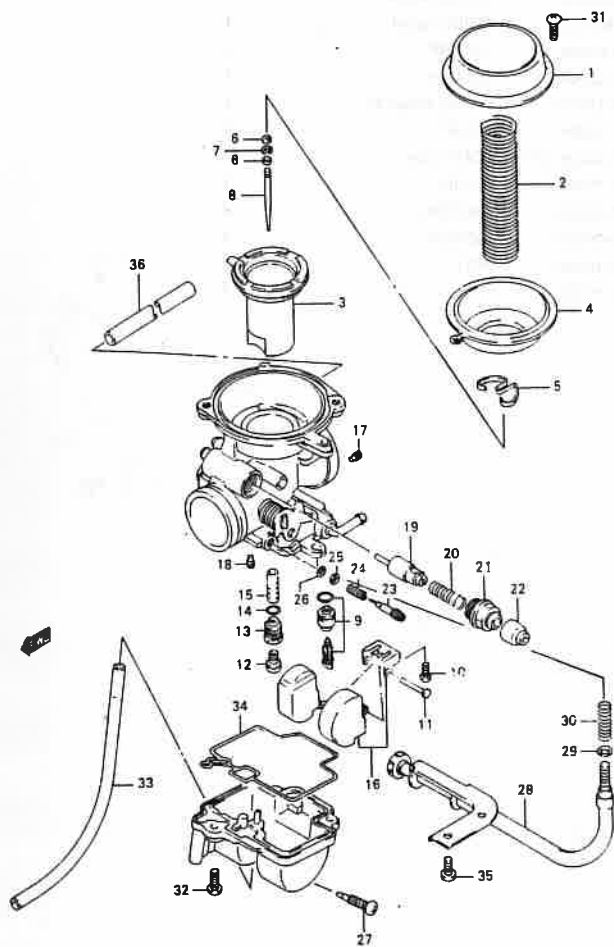


FIG. 11

FIG. 11 (C-3) CARBURETOR

REF. NO.	PART NO.	DESCRIPTION	QTY	REMARKS
33	13684-47E00	.HOSE (3x5x320)	1	
34	13251-47E00	.GASKET, float body	1	
35	02112-04083	.SCREW	3	
36	09352-40703-600	.HOSE (4x7x600)	1	L: 600-325



2

FIG. 12

2

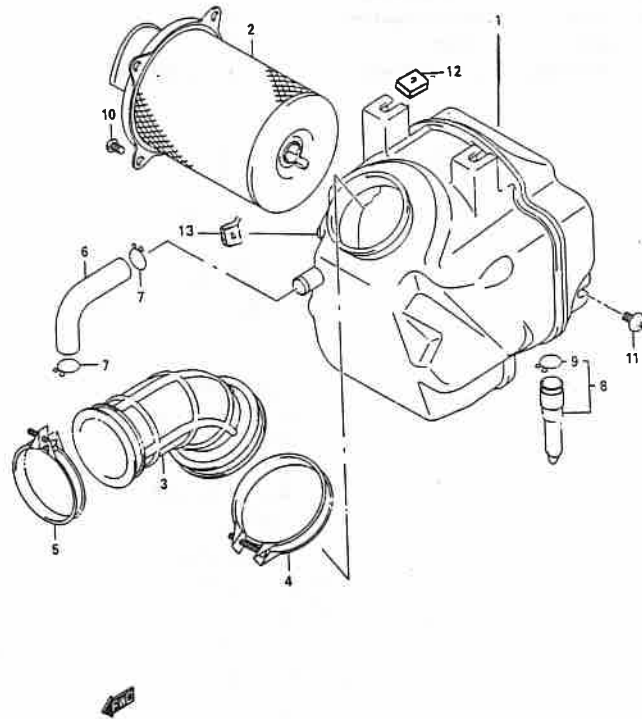
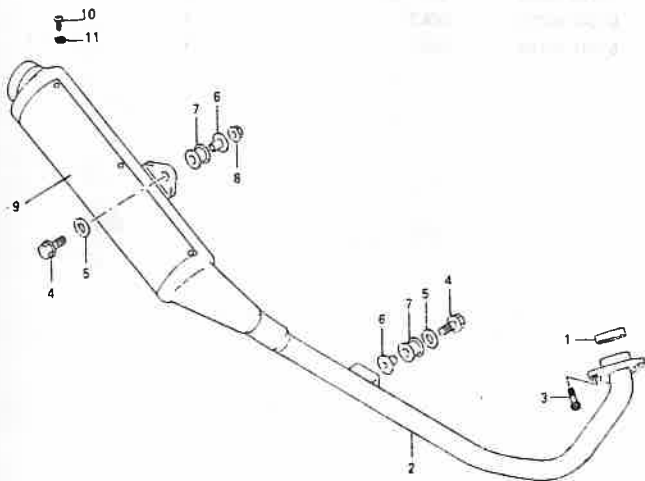


FIG. 12 (C-4) AIR CLEANER

REF. NO.	PART NO.	DESCRIPTION	Q'TY	REMARKS
1	13720M47E10	CASE CLEANER ASSY, air	1	
2	13780-47E00	.FILTER ASSY	1	
3	13881M47E00	.TUBE, outlet	1	
4	09402-62208	.CLAMP	1	
5	09402-52208	.CLAMP	1	
6	13850-47E00	.TUBE, breather	1	
7	09401-14301	..CLIP	1	
8	13872-00A00-010	.CAP, drain	1	
9	13824-00A00	..CLIP	1	
10	02142-05103	.SCREW	4	
11	02142-06123	SCREW	3	
12	13836-42A00	NUT	3	
13	13832-11036	NUT	4	

FIG. 13

FIG. 13 (C-5) MUFFLER



REF. NO.	PART NO.	DESCRIPTION	Q'TY	REMARKS
1	14181M18C00	GASKET, exhaust pipe	1	
2	14305M47E10	MUFFLER	1	
3	07130-08253	BOLT	2	
4	01570-08353	BOLT	2	
5	09160-08032	WASHER (8.5x26x1.2)	2	
6	14773M41D00	SPACER	2	
7	09320M12058	CUSHION	2	
8	08319-31083	NUT	1	
9	14781M47E00	COVER MUFFLER	1	
10	02142M06087	BOLT MUF. COVER	6	
11	08321M01063	WASHER MUF. COVER	6	

2

FIG. 14

2

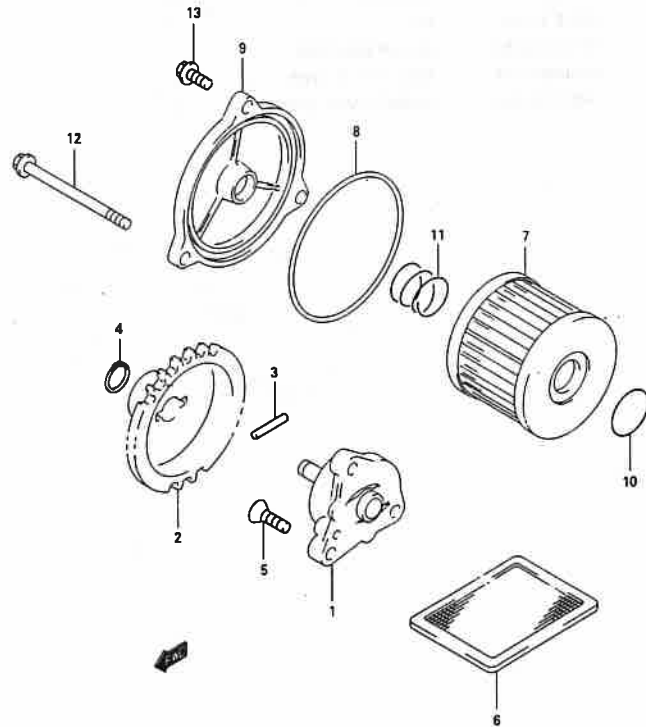


FIG. 14 (C-6) OIL PUMP

REF. NO.	PART NO.	DESCRIPTION	Q'TY	REMARKS
1	16400-47E10	PUMP ASSY, engine oil	1	
2	16331-47E00	GEAR, oil pump driven (NT:30)	1	
3	09261-02001	PIN (2.5x19.8)	1	
4	08332-11063	CIRCLIP	1	
5	02122-06203	SCREW	3	
6	16520-30A00	STRAINER, engine oil	1	
7	16510-05240	FILTER, engine oil	1	
8	09280-54001	O RING (D: 2.4, ID: 52.6)	1	
9	16512-47E00	CAP, OIL FILTER	1	
10	09280-13004	O RING (D:1.9, ID: 13)	1	
11	09440-18002	SPRING	1	
12	01547-06703	BOLT	2	
13	01547-06163	BOLT	1	

FIG. 15

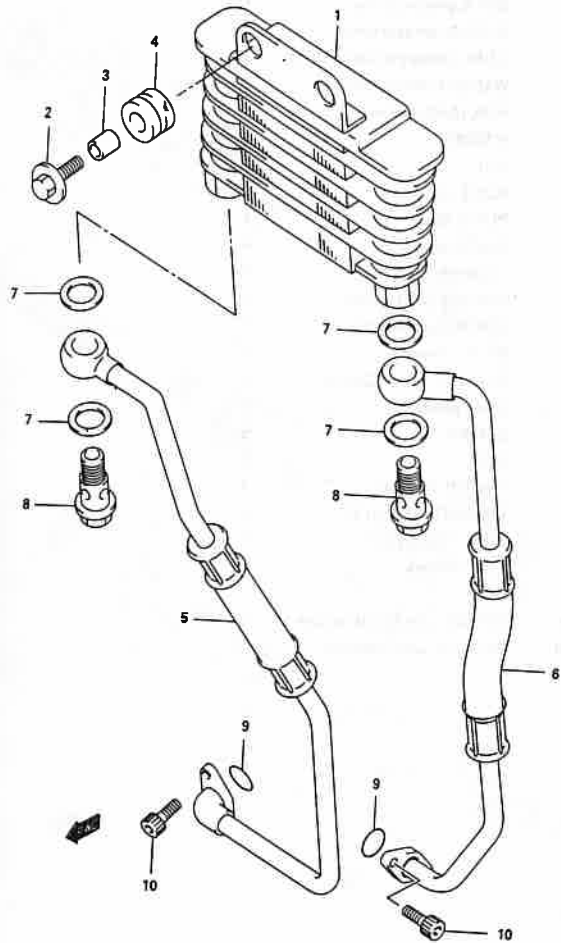


FIG. 15 (C-7) OIL COOLER

REF. NO.	PART NO.	DESCRIPTION	Q'TY	REMARKS
1	16600-41E00	COOLER ASSY, oil	1	
2	09116-06143	BOLT (6x20)	2	
3	09180-06310	SPACER	2	
4	09320-10015	CUSHION	2	
5	16460-47E00	HOSE, oil cooler R	1	
6	16470-47E00	HOSE, oil cooler L	1	
7	09168-14011	GASKET, hose no. 2	4	
8	09360-12006	BOLT, union (12x28)	2	
9	09280-12008	O RING	2	
10	07130-06163	BOLT	4	

2

FIG. 16

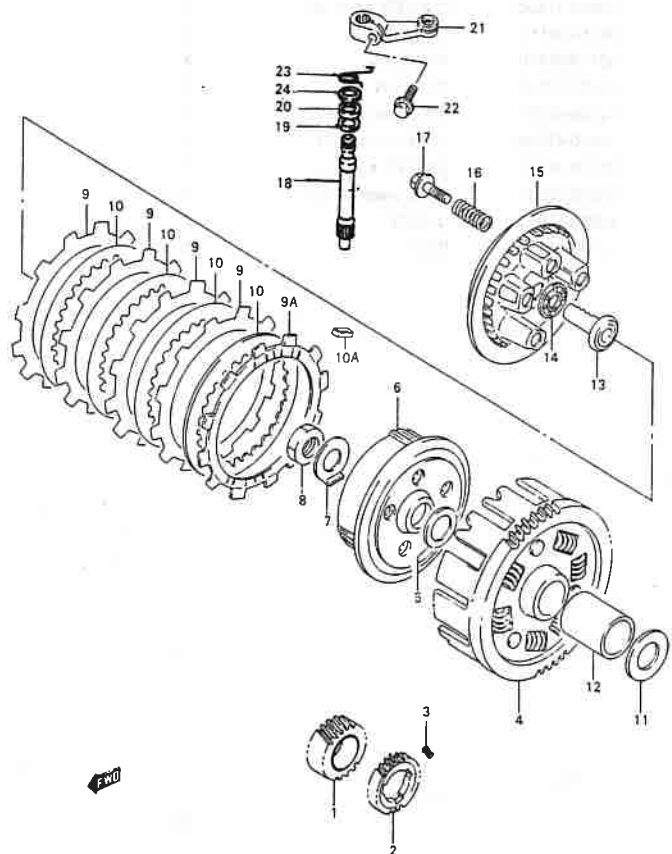


FIG. 16 (D-2) CLUTCH

REF. NO.	PART NO.	DESCRIPTION	Q'TY	REMARKS
1	21111-35C20	GEAR, primary drive	1	
2	21112-35C00	GEAR, primary drive	1	
3	21114-35C00	SPRING, primary drive	3	
4	21200-35C30	GEAR, primary driven (NT: 70)	1	
5	08211-20352	WASHER, clutch sleeve	1	
6	21411-05200	HUB, clutch sleeve	1	
7	09169-16003	WASHER	1	
8	09140-16005	NUT	1	
9	21441-13A01	PLATE, drive	4	
9A	21442-13A00	PLATE, drive	1	
10	21451-19A00	PLATE, driven	4	
10A	21483-13A00	DAMPER, drive	4	
11	09160-20056	SPACER (20.1x36x4)	1	
12	21251-13E00	SPACER, primary driven	1	
13	23165-48000	RACK, release	1	
14	09263-10002	BEARING (10.1x22x2.8)	1	
15	21462-02B40	DISK, pressure	1	
16	09440-15036	SPRING	5	
17	09116-05003	BOLT	5	
18	23261-13A01	PINTON, release	1	
19	09160-12086	WASHER (12.5x17x1)	1	
20	09285-10004	SEAL (10x17x5)	1	
21	23271-03D10	ARM, release	1	
22	01500-06163	BOLT	1	
23	23271M21D99C	SPRING, arm clutch release	1	
24	23271M21D98B	WASHER, arm clutch rel.	1	

FIG. 17

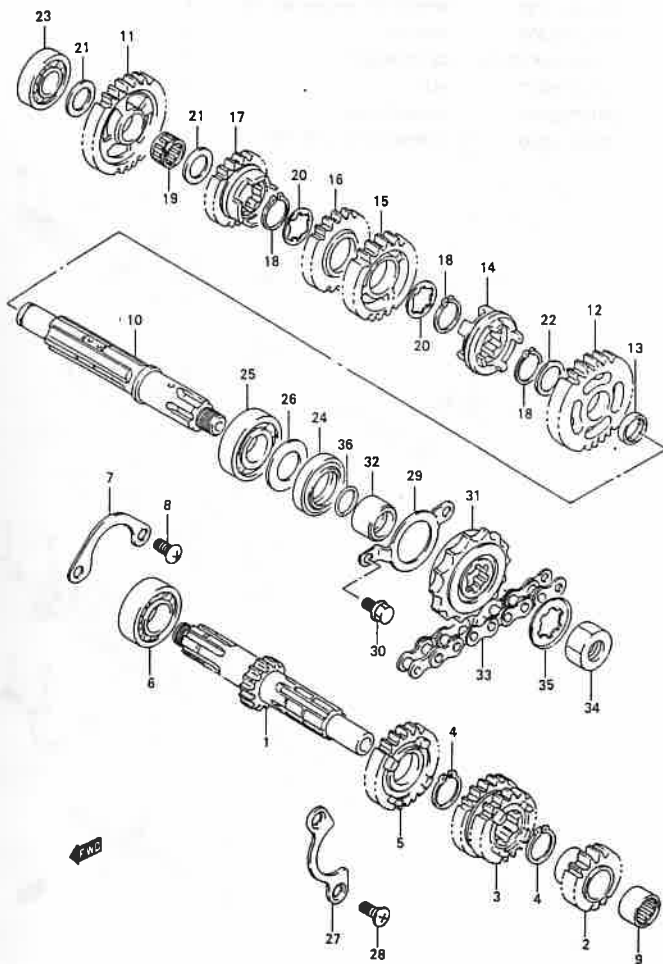


FIG. 17 (D-3) TRANSMISSION

REF. NO.	PART NO.	DESCRIPTION	Q'TY	REMARKS
1	24121-05220	COUNTERSHAFT (NT: 12)	1	
2	24221-29B01	GEAR, 2nd drive (NT: 14)	1	
3	24231-05203	GEAR, 3rd & 4th (NT: 19/21)	1	
4	09380-20009	CIRCLIP, 5th	1	
5	24251-05203	GEAR, 5th drive (NT: 23)	1	
6	09262-20019	BEARING, counter shaft RH	1	20x47x14
7	24741-12B00	RETAINER, counter bearing	1	
8	02112-06123	SCREW	2	
9	08123-60027	BEARING, countershaft LH	1	
10	24130-05330	SHAFT, drive	1	
11	24311-29B01	GEAR, 1st driven (NT: 33)	1	
12	24321-29B20	GEAR, 2nd driven (NT: 25)	1	
13	24322-47E00	BUSH, 2nd driven	1	
14	24421-05300	WHEEL, sliding dog	1	
15	24331-05203	GEAR, 3rd driven (NT: 26)	1	
16	24341-05203	GEAR, 4th driven (NT: 23)	1	
17	24351-05202	GEAR, 5th driven (NT: 21)	1	
18	09380-20009	CIRCLIP, 2nd/3rd/4th driven	3	
19	09263-15023	BEARING, 1st driven	1	15x19x7.8
20	09167-20011	WASHER, 3rd/4th driven	2	20.5x25x0.5
21	08211-15251	WASHER, 1st driven	2	
22	09181-20167	WASHER, 2nd driven	1	20x28x1.0
23	08113-62027	BEARING, RH	1	
24	09283-27010	OIL SEAL (27x40x6)	1	
25	09262-20019	BEARING, LH (20x47x14)	1	
26	24359-05200	WASHER, oil sealing	1	
27	24741-05200	RETAINER, driveshaft	1	
28	02122-06123	SCREW	2	
29	24751-05210	RETAINER, drive shaft	1	
30	01500-06103	BOLT	2	

2

FIG. 17

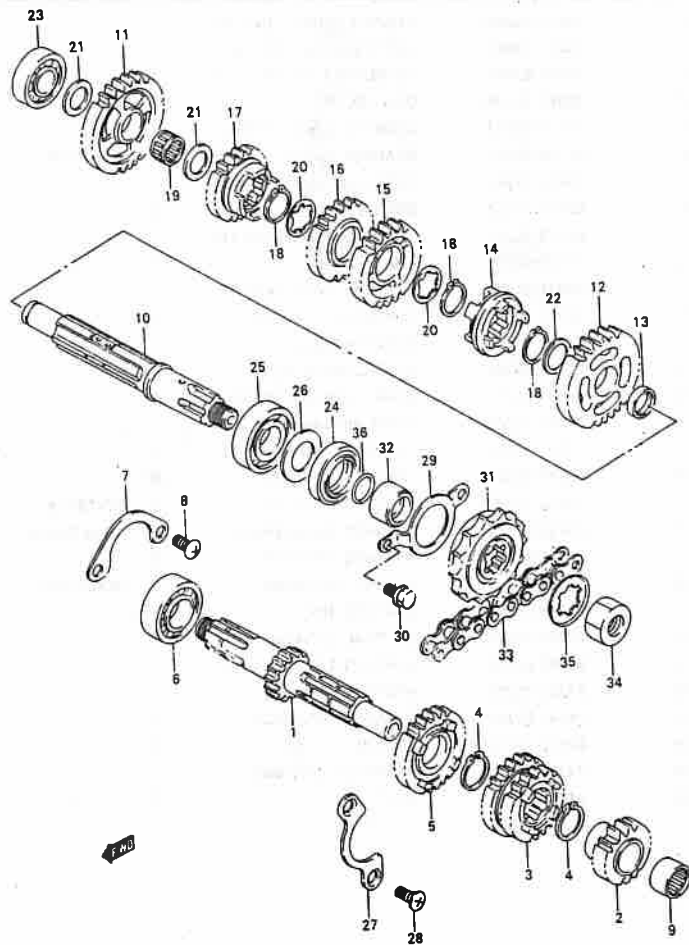


FIG. 17 (D-4) TRANSMISSION

REF. NO.	PART NO.	DESCRIPTION	Q'TY	REMARKS
31	27510-41730	SPROCKET, engine (NT: 14)	1	
32	27531-05200	SPACER	1	
33	27600M36012-122	CHAIN ASSY	1	
34	09140-16017	NUT	1	
35	09167-20030	WASHER, lock	1	
36	09280-19005	O-RING (D: 2.4, ID: 19)	1	

FIG. 18

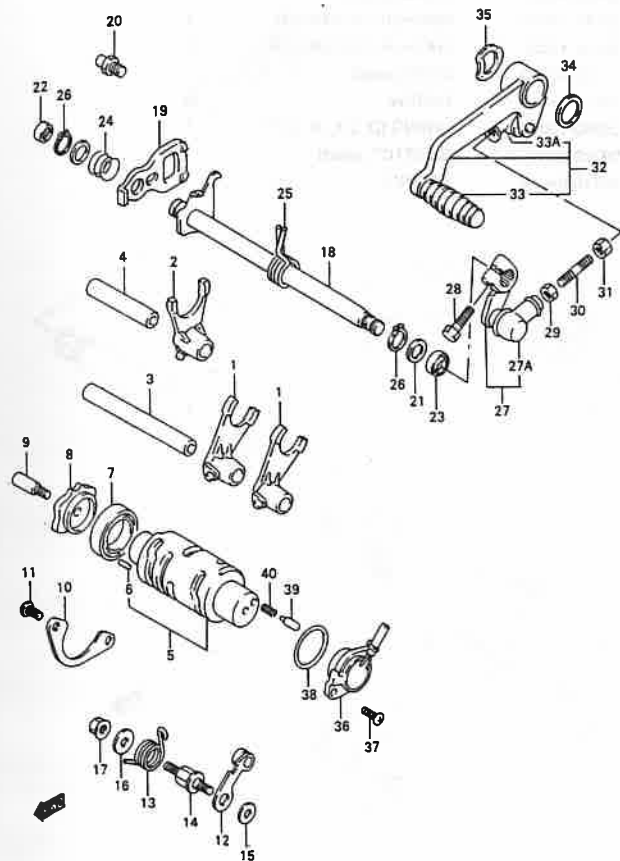


FIG. 18 (D-5) GEAR SHIFTING

REF. NO.	PART NO.	DESCRIPTION	QTY	REMARKS
1	25221-08300	FORK, gear shifting, no. 1	2	
2	25231-47E00	FORK, gear shifting, no. 3	1	
3	25411-21D01	SHAFT, gear shifting no. 1	1	
4	25421-35403	SHAFT, gear shifting no. 2	1	
5	25310-47E00	CAM, gear shifting	1	
6	04221-04089	.PIN	1	
7	08113-69050	BEARING, gear shift cam	1	
8	25301-13E10	PLATE, gear shift cam	1	
9	25312-12C00	STOPPER, shift cam	1	
10	24741-12B00	RETAINER	1	
11	02112-06123	SCREW	2	
12	25350-26D01	STOPPER, CAM	1	
13	25355-26D21	SPRING, stopper	1	
14	25356-12C00	SUPPORT, cam stopper	1	
15	08211-06141	WASHER, cam stopper	1	
16	08211-06181	WASHER, CAM ARM	1	
17	08316-10063	NUT, cam	1	
18	25510-47E20	SHAFT, gear shifting	1	
19	25512-13E11	PLATE, gear shift cam	1	
20	25671-01000	STOPPER, gear shift	1	
21	09181-14167	WASHER (14x22x1)	2	
22	09263-14027	BEARING, LH (14x20x12)	1	
23	09283-14006	SEAL (14x22x6)	1	
24	09440-17009	SPRING	1	
25	09444-20001	SPRING	1	
26	08331-31146	CIRCLIP, gear shift	2	
27	25520-12C10	ARM, gear shift link	1	
27A	25526-47000	.COVER, dust	1	
28	01500-06203	BOLT	1	
29	08310-00067	NUT	1	
30	25525-20A10	ROD, gear shift link	1	
31	09140-06025	NUT	1	

2

FIG. 18

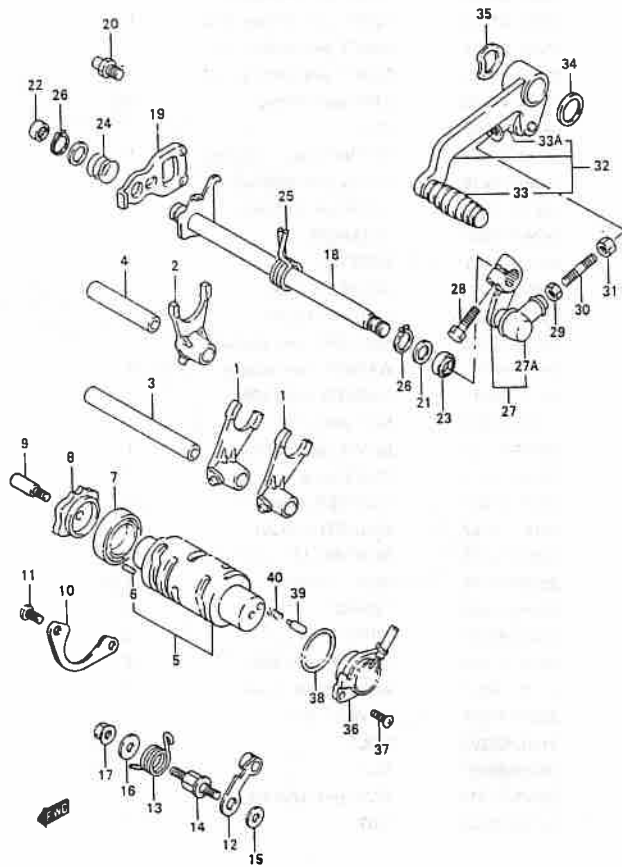


FIG. 18 (D-6) GEAR SHIFTING

REF. NO.	PART NO.	DESCRIPTION	Q'TY	REMARKS
32	25600-47E00	LEVER ASSY, gear shifting	1	
33	25652M16500	.RUBBER, pedal	1	
33A	25526-47000	.COVER, dust	1	
34	09161-18005	WASHER (18.2x26x0.8)	1	
35	09164-18002	WASHER (18.7x26x0.3)	1	
36	37720-47E00	BODY, switch	1	
37	02112-05163	SCREW	2	
38	09280-26007	O RING (D: 2.4, ID: 25.7)	1	
39	09209-05011	CONTACT, switch	1	
40	09440-04010	SPRING	1	

2

FIG. 19

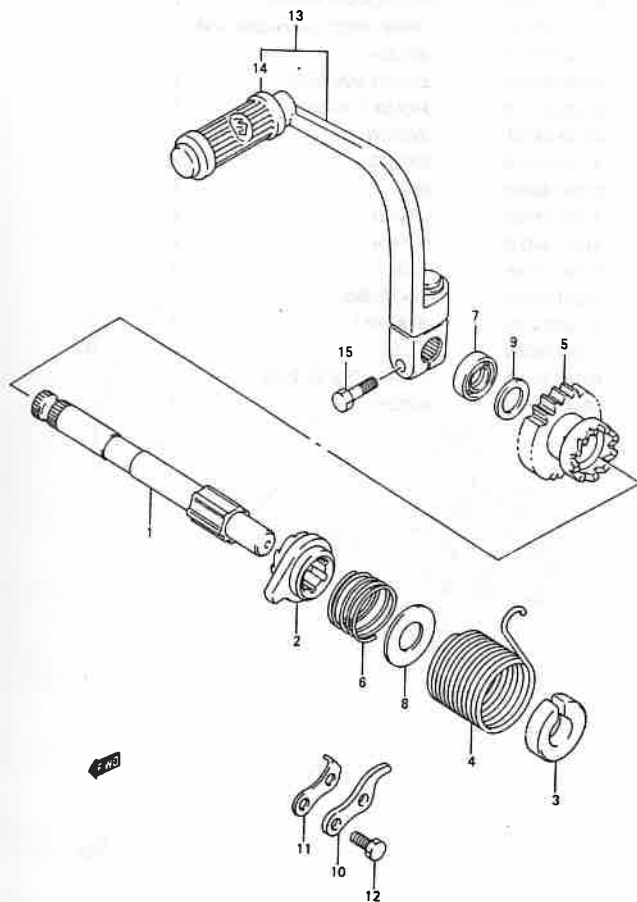


FIG. 19 (D-7) KICK STARTER

REF. NO.	PART NO.	DESCRIPTION	Q'TY	REMARKS
1	26211-47E10	SHAFT, kick starter	1	
2	26231-09410	STARTER, kick	1	
3	26221M30A00	GUIDE, spring	1	
4	09448-38004	SPRING	1	
5	26241-47E00	GEAR, drive (NT: 18)	1	
6	09440-30007	SPRING	1	
7	09285-16003	OIL SEAL (16x24x5)	1	
8	08211-14321	WASHER	1	
9	09181-16223	WASHER (16x28x1)	1	
10	26232-09401	GUIDE, kick starter	1	
11	26233-09400	STOPPER, kick starter	1	
12	01500-06123	BOLT	2	
13	26300M47E00	LEVER ASSY, kick starter	1	
14	26352M01000	.RUBBER	1	
15	01500-08253	BOLT	1	

2

FIG. 20

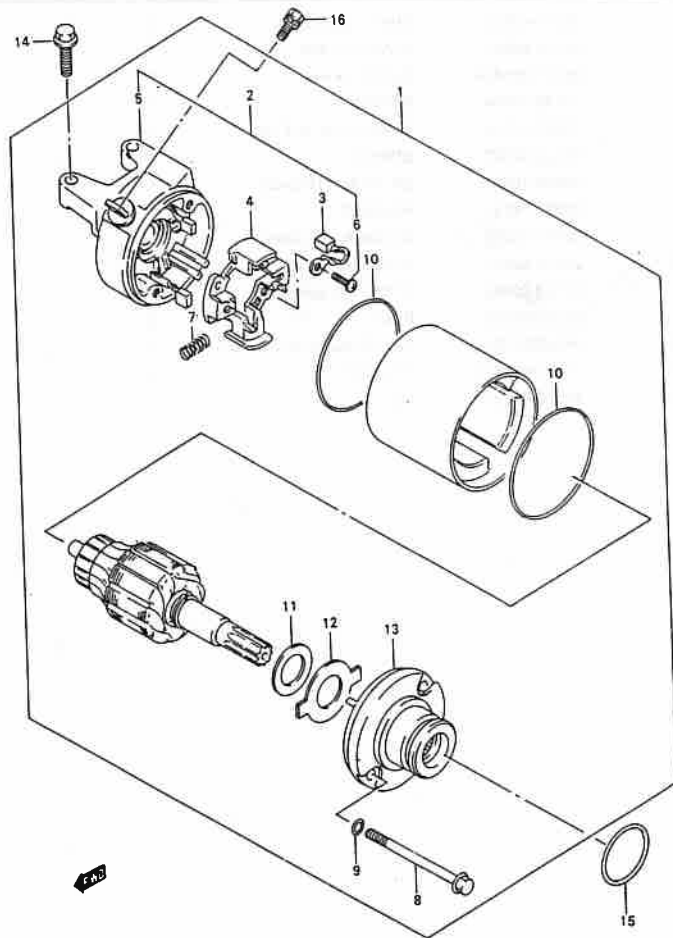


FIG. 20 (E-2) STARTING MOTOR

REF. NO.	PART NO.	DESCRIPTION	QTY	REMARKS
1	31100-47E00	MOTOR ASSY, starting	1	
2	31175-47E00	.FRAME ASSY, commutator, end	1	
3	31132-32C10	..BRUSH	2	
4	31130-32C20	..BRUSH SUB ASSY	1	
5	31133-32C10	..HOLDER, brush	1	
6	02112-34123	..SCREW	3	
7	31135-32C10	..SPRING	4	
8	31281-20E00	..BOLT	2	
9	31156-38300	..O RING	2,	
10	31264-32C10	..O RING	2	
11	31361-38300	..SHIM	1	
12	31361-32C10	..PLATE, lock	1	
13	31150-06C00	..BRACKET	1	
14	01547-06253	BOLT	2	
15	09180-24003	O RING (D:3, ID: 24.5)	1	
16	09137-05004	SCREW	1	

2

FIG. 21

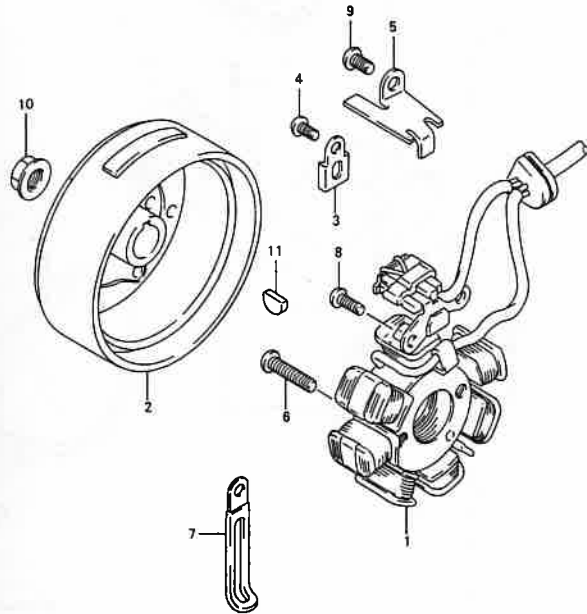
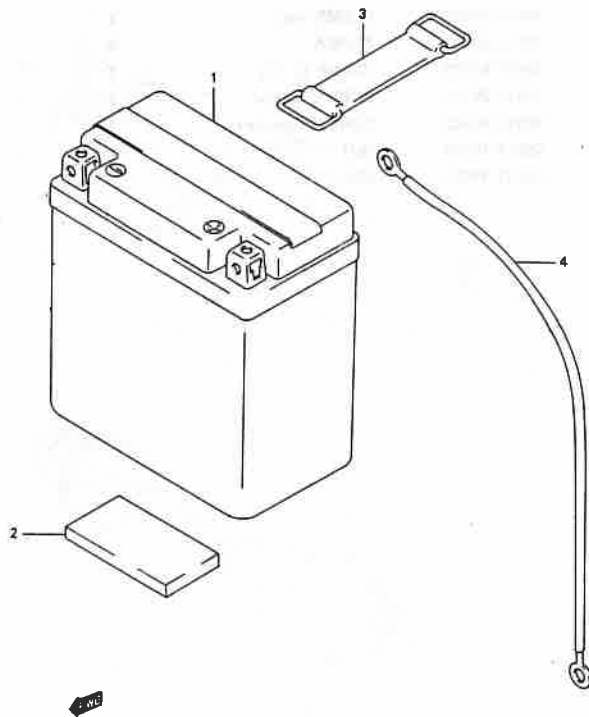


FIG. 21 (E-3) MAGNETO

REF. NO.	PART NO.	DESCRIPTION	Q'TY	REMARKS
1	32101-47E00	STATOR ASSY	1	
2	32102-47E00	ROTOR ASSY	1	
3	31497-45000	CLAMP, sensor	1	
4	02112-05103	SCREW	1	
5	32371-30D00	CLAMP, mag	1	
6	02112-06203	SCREW	2	
7	09404-06429	CLAMP (L: 60)	1	
8	02112-05103	SCREW, sensor	2	
9	02112-06103	SCREW, mag clamp	1	
10	08316-10123	NUT	1	
11	08341-31039	KEY	1	

3

FIG. 22



3

FIG. 22 (E-4) BATTERY

REF. NO.	PART NO.	DESCRIPTION	Q'TY	REMARKS
1	33610M40D50-DRY	BATTERY (FTX5L-BS, 12V, 4AH)	1	
2	33652M35400	PROTECTOR (20x50x8)	1	
3	09462M00073	BAND	1	
4	33820M47E10	WIRE, battery plus	1	

FIG. 23

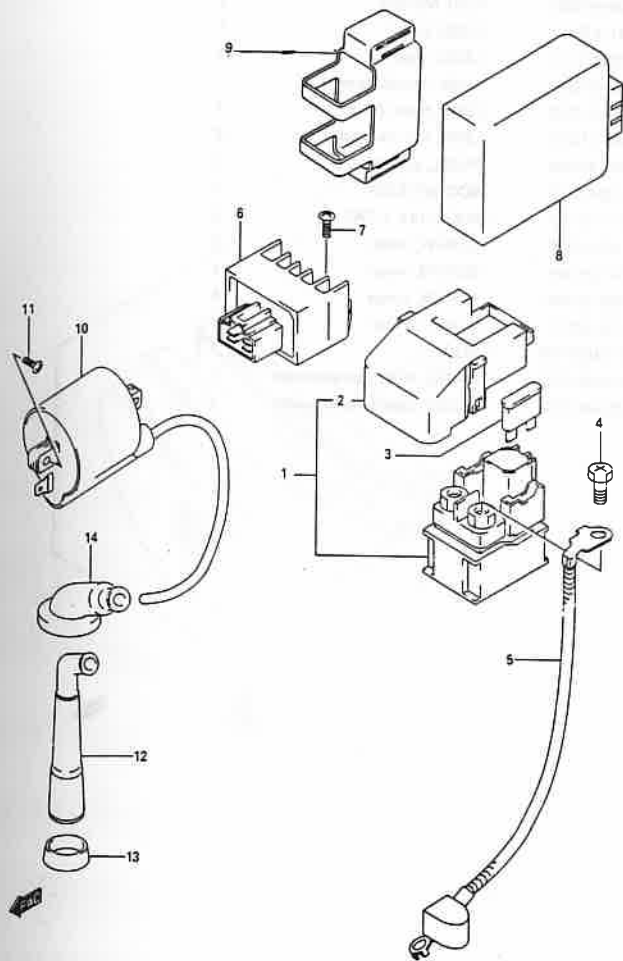


FIG. 23 (E-5) ELECTRICAL

REF. NO.	PART NO.	DESCRIPTION	Q'TY	REMARKS
1	31800-47E00	RELAY, starting motor	1	
2	31861-47E00	.COVER	1	
3	09481-20102	.FUSE (20A)	2	
4	09128-06013	SCREW (6x10)	2	
5	33810M47E00	LEAD WIRE, starting motor	1	
6	32800-47E00	RECTIFIER ASSY	1	
7	02112-06123	SCREW	1	
8	32900-47E00	CDI UNIT	1	
9	32980M44A10	CUSHION	1	
10	33410-03D00	COIL, ignition	1	
11	02112-06163	SCREW	2	
12	33510-48B10	CAP, spark plug	1	
13	33541-23E01	SEAL, spark plug	1	
14	33542-47E00	SEAL, hightension cord	1	

3

FIG. 24

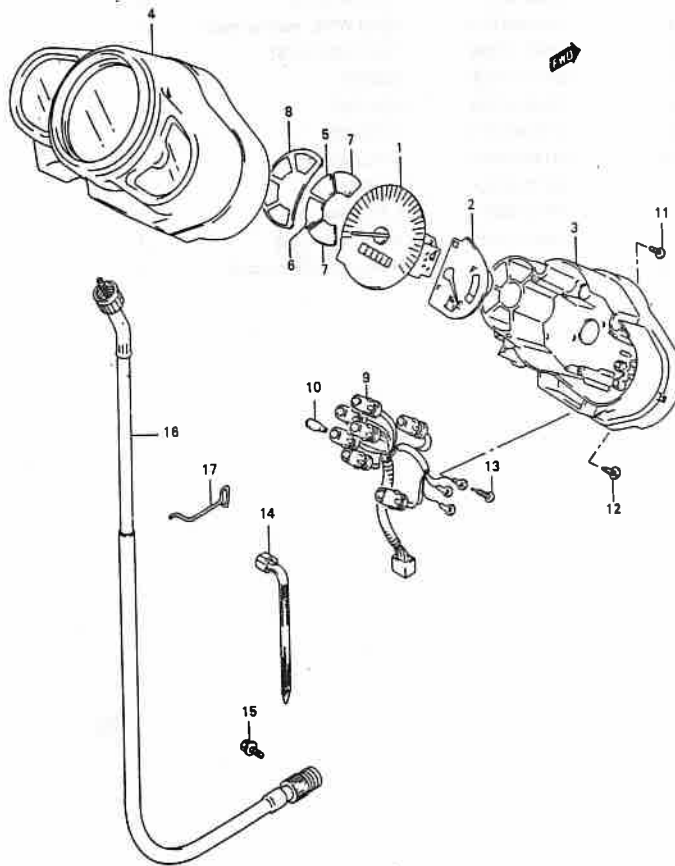


FIG. 24 (E-6) SPEEDOMETER

REF. NO.	PART NO.	DESCRIPTION	Q'TY	REMARKS
1	34120-47E00	SPEEDOMETER	1	
2	34320-47E00	FUEL METER	1	
3	34111-47E10	CASE, lower	1	
4	34112-47E10	CASE, upper	1	
5	36321-21D30	LENS, neutral (green)	1	
6	36331-21D30	LENS, beam (blue)	1	
7	36341-21D30	LENS, turn (orange)	2	
8	36343-47E00	PANEL, pilot lamp	1	
9	34173-47E10	SOCKET ASSY	1	
10	09471-12100	BULB (14V, 1.7W)	6	
11	34147-21D30	SCREW, meter	2	
12	03541-05163	SCREW, meter	4	
13	34383-21D30	SCREW, meter	3	
14	34176-47E10	CLAMP, meter	1	
15	01514M06105	BOLT	1	
16	34910M47E10	CABLE ASSY, speedometer	1	
17	34938M47E00	GUIDE, speedometer cable	1	

3

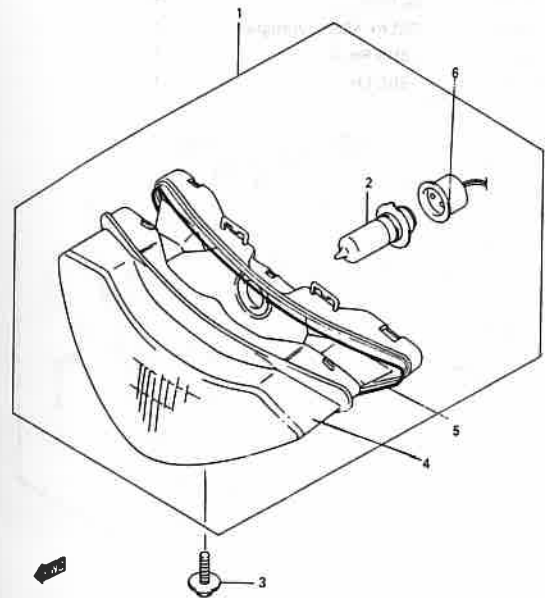
FIG. 25

FIG. 25 (E-7) HEADLAMP

FIG. 25

REMARKS

EXPLANATION



REF. NO.	PART NO.	DESCRIPTION	Q'TY	REMARKS
1	35100M47E10	HEADLAMP ASSY	1	
2	09471M12124	.BULB (12V, 30/30W)	1	
3	09136-05051	BOLT (5x12)	1	
4	35124M47E10	LENS H/LAMP	1	
5	35125M47E10	GASKET HEADLAMP	1	
6	35171M47E00	SOCKET H/LAMP	1	

3

FIG. 26

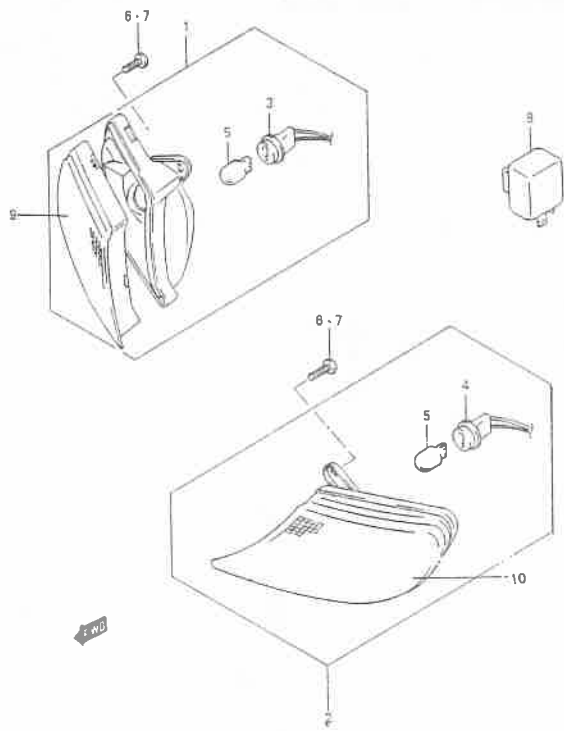
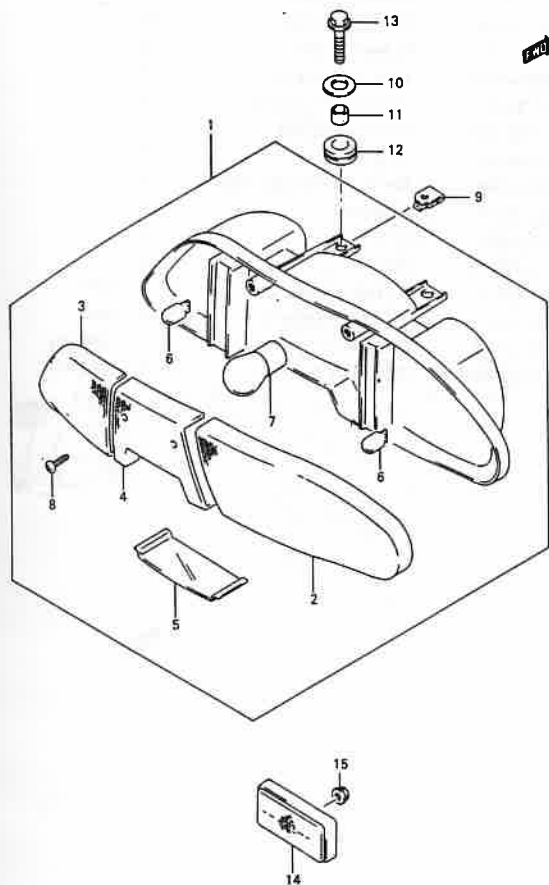


FIG. 26 (E-8) FRONT TURN SIGNAL

REF. NO.	PART NO.	DESCRIPTION	Q'TY	REMARKS	
24 20	1	35601M47E00	LAMP ASSY, front RH	1	
2	35602M47E00	LAMP ASSY, front LH	1		
3	35615M47E00	.UNIT ASSY, RH	1		
4	35613M47E00	.UNIT ASSY, LH	1		
5	09471M12114	.BULB (12V, 10W)	2		
6	03541-04123	SCREW	2		
7	03541-04163	SCREW	4		
8	38610-09410	RELAY ASSY, turnsignal	1		
9	35612M47E00	LENS RH	1		
10	35632M47E00	LENS LH	1		

FIG. 27

FIG. 27 (E-9) REAR COMBINATION LAMP



REF. NO.	PART NO.	DESCRIPTION	Q'TY	REMARKS
1	35710M47E10	LAMP ASSY, rear comb	1	
2	35652M47E10	.LENS, turn RH	1	
3	35672M47E10	.LENS, turn LH	1	
4	35712M47E10	.LENS, tail & stop	1	
5	35912M47E10	.LENS, license	1	
6	09471M12114	.BULB (12V, 10W)	2	
7	09471M12119	.BULB (12V, 18/5W)	1	
8	03511M04163	.SCREW	2	
9	09148-05004	NUT	2	
10	09160-06131	WASHER (6.5x16x4)	2	
11	09180M06248	SPACER (6.1x8x9.5)	2	
12	09320M08048	CUSHION	2	
13	01550-06253	BOLT	2	
14	35970M05F00	REFLEX REFLECTOR ASSY, RR	1	
15	08316-10053	NUT	1	

3

FIG. 28

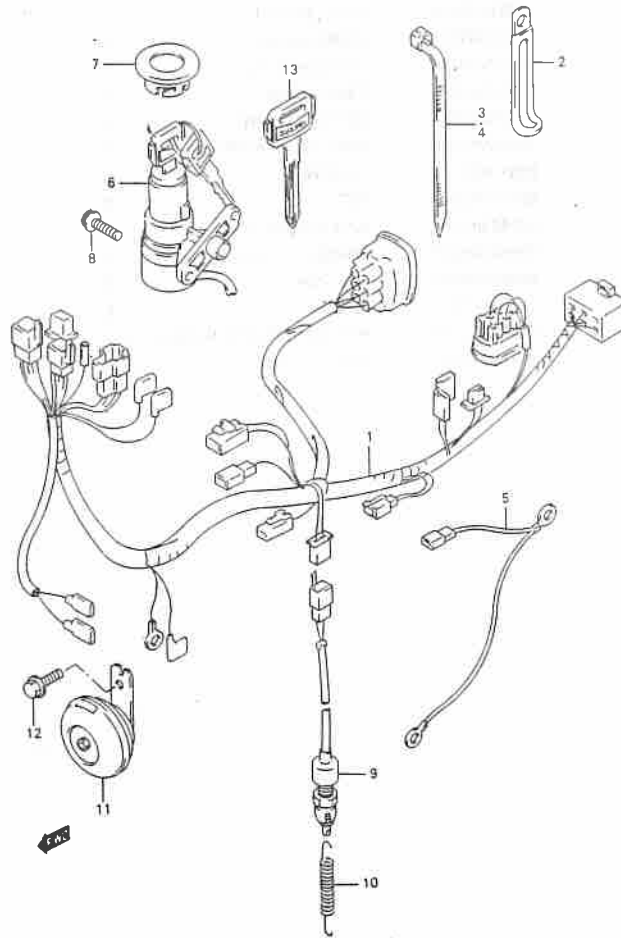


FIG. 28 (E-10) WIRING HARNESS

REF. NO.	PART NO.	DESCRIPTION	Q'TY	REMARKS
1	36610M47E20	HARNNESS, wiring	1	
2	09404-06429	CLAMP (L:60)	1	
3	09407-18403	CLAMP (L: 165)	3	
4-1	09407-14403	CLAMP (L: 125)	4	
4-2	09407-25401	CLAMP (L: 235)	1	
5	33860M47E00	WIRE, engine earth	1	
6	37100-30D20	LOCK ASSY, steering	1	
7	37155M31C00	CAP, steering lock	1	
8	01550-06163	SCREW	2	
9	37740-31D00	SWITCH ASSY, stop lamp	1	
10	09443-06075	SPRING	1	
11	38500-16D22	HORN ASSY	1	
12	01514M06125	BOLT	1	
13-1	37146-03A00	KEY, blank (type C)	1	OPT
13-2	37146-03A10	KEY, blank (type D)	1	OPT
13-3	37146-03A20	KEY, blank (type E)	1	OPT
13-4	37146-03A30	KEY, blank (type F)	1	OPT

3

FIG. 29

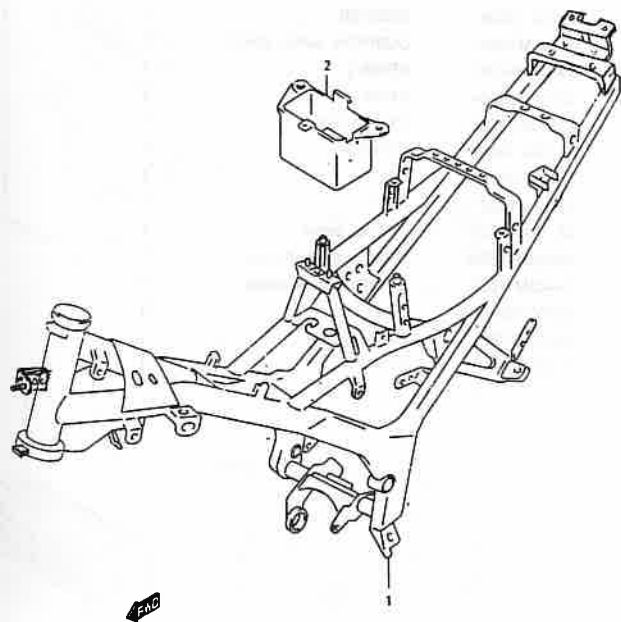


FIG. 29 (F-2) FRAME

REF. NO.	PART NO.	DESCRIPTION	Q'TY	REMARKS
1	41100M47E10	FRAME	1	
2	41541M47E00	HOLDER, battery	1	

4

FIG. 30

4

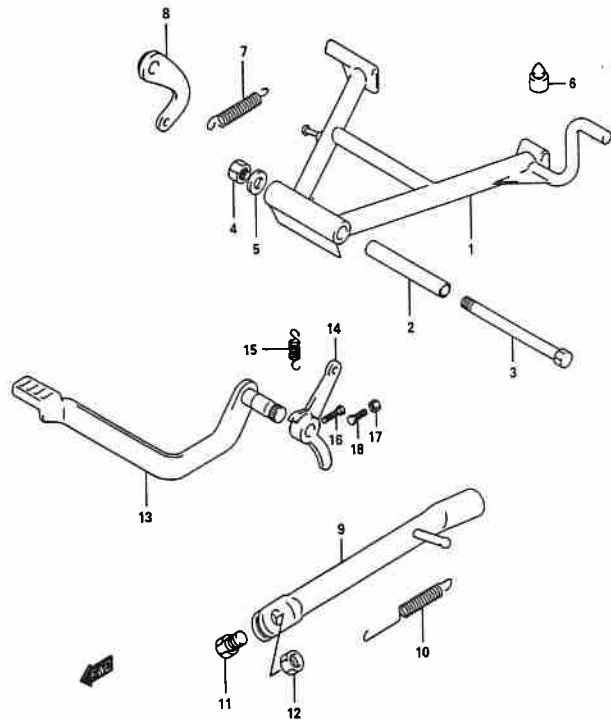


FIG. 30 (F-3) STAND - BRAKE PEDAL

REF. NO.	PART NO.	DESCRIPTION	QTY	REMARKS
1	42100M47E00	STAND, center	1	
2	42211M03001	SPACER, center stand	1	
3	42129-21D00	BOLT	1	
4	08319-21108	NUT	1	
5	09160-10005	WASHER	1	
6	09321M10001	CUSHION, center stand	1	
7	09443M16007	SPRING	1	
8	42251M03004	HOOK	1	
9	42310M47E00	STAND, prop	1	
10	09443M14022	SPRING	1	
11	09111-10014	BOLT	1	
12	09159-10097	NUT	1	
13	43110M47E00	PEDAL, brake	1	
14	43120M47E00	ARM, brake pedal rod	1	
15	09443M11033	SPRING, brake pedal	1	
16	09100-06153	BOLT	1	
17	08310-00063	NUT, adjuster	1	
18	01500-06163	BOLT	1	

FIG. 31

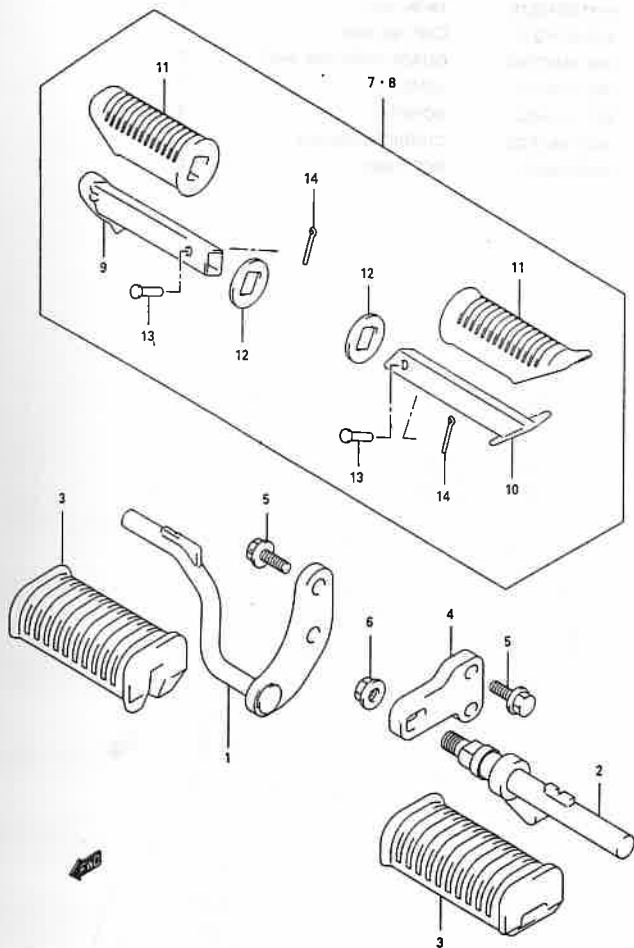


FIG. 31 (F-4) FOOTREST

REF. NO.	PART NO.	DESCRIPTION	QTY	REMARKS
1	43510M47E00	BRACKET COMP, frt footrest RH	1	
2	43520M47E00	BAR COMP, frt footrest LH	1	
3	43551M39110	.RUBBER	2	
4	43540M47E00	BRACKET, front footrest LH	1	
5	01550-08203	BOLT	4	
6	08319-31103	NUT, bar	1	
7	43600M21D00	FOOTREST ASSY, pillion RH	1	
8	43700M21D00	FOOTREST ASSY, pillion LH	1	
9	43610M34A00	.BAR, pillion footrest RH	1	
10	43710M34A00	.BAR, pillion footrest LH	1	
11	43612M21D00	.RUBBER	2	
12	43631M34A01	.WASHER	2	
13	09200-06057	.PIN	2	
14	04111-25158	.COTTER PIN	2	

4

FIG. 32

4

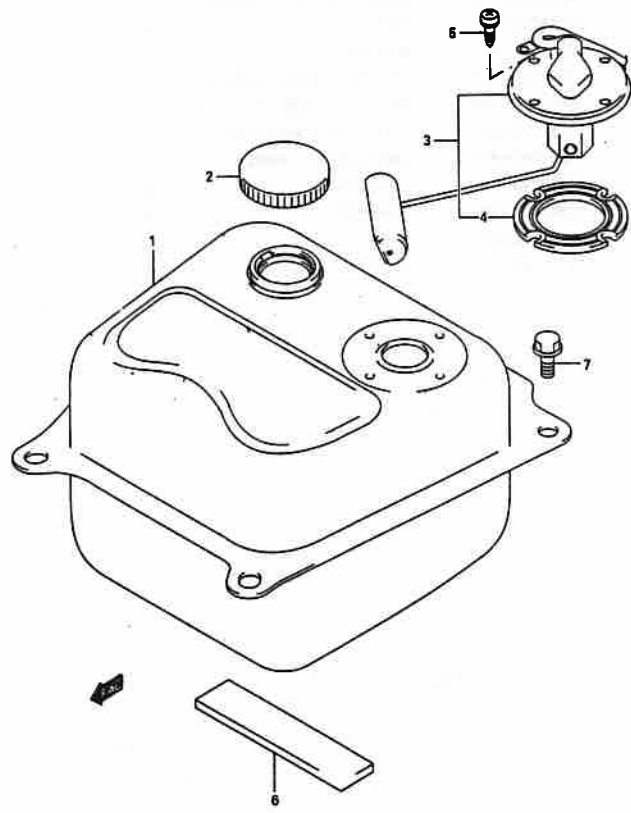


FIG. 32 (F-5) FUEL TANK

REF. NO.	PART NO.	DESCRIPTION	QTY	REMARKS
1	44110M47E10	TANK, fuel	1	
2	44210-24D10	CAP, fuel tank	1	
3	34810M47E00	GUAGE ASSY, fuel level	1	
4	34825-02100	.GASKET	1	
5	02112-35123	SCREW	4	
6	44281M29C00	CUSHION, fuel tank	2	
7	01550-06183	BOLT, rear	2	

FIG. 33

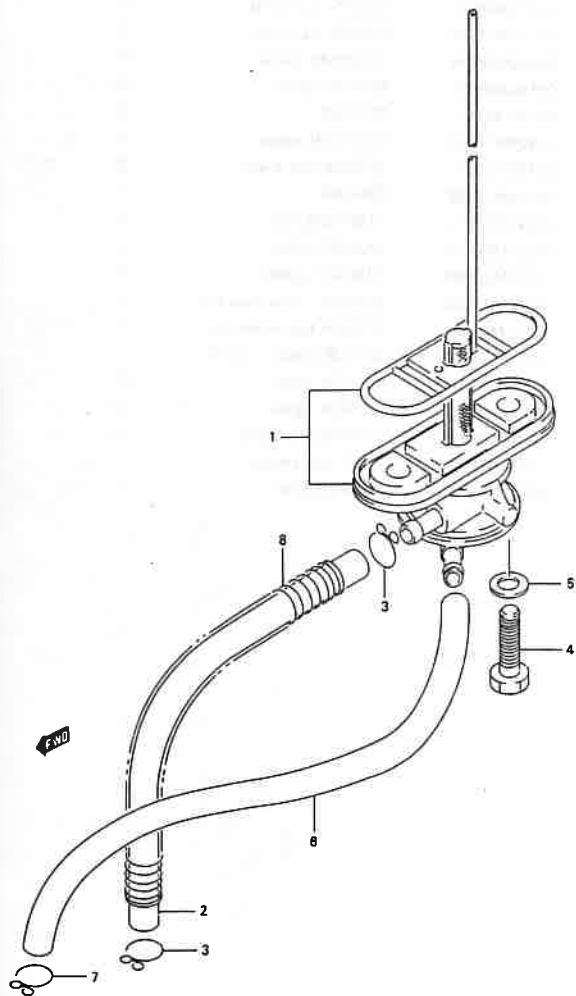


FIG. 33 (F-6) FUEL COCK

REF. NO.	PART NO.	DESCRIPTION	Q'TY	REMARKS
1	44300-21D00	COCK ASSY, fuel	1	
2	09355-50105-400	HOSE, fuel	1	
3	09401-09403	CLIP, fuel hose	2	
4	09128-06035	SCREW, fuel cock	2	
5	09168-06026	GASKET, fuel cock	2	
6	09352-50823-600	HOSE, vacuum (L:600-580)	1	
7	09401-08401	CLIP, vacuum hose	2	
8	09440M13027	SPRING, fuel hose	1	

4

FIG. 34

4

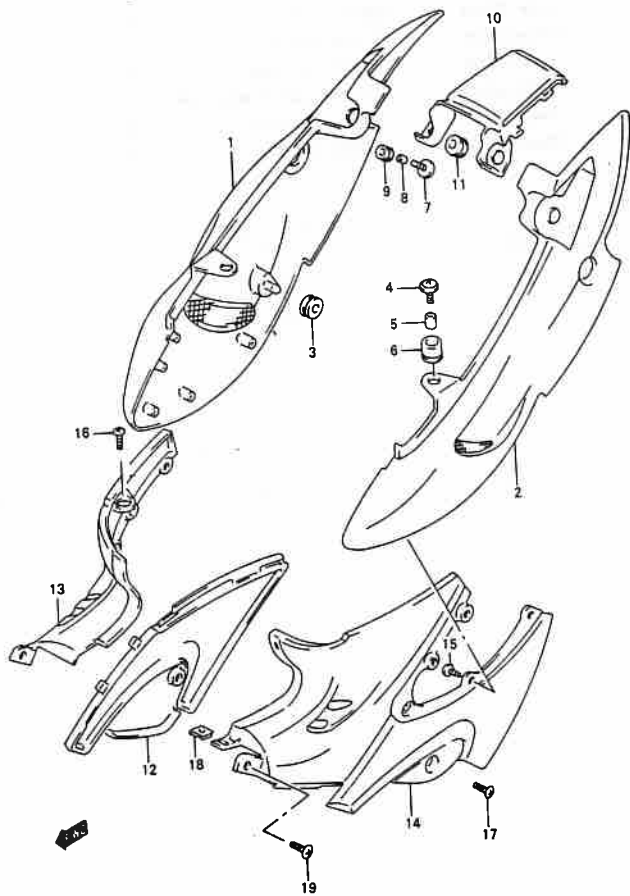


FIG. 34 (G-2) FRAME COVER

REF. NO.	PART NO.	DESCRIPTION	Q'TY	REMARKS
1	47111M47E10	COVER, frame RH	1	
2	47211M47E10	COVER, frame LH	1	
3	09320M08018	CUSHION, center	2	
4	09136-06105	SCREW, upper	2	
5	09180-06167	SPACER	2	
6	09320M10045	CUSHION, upper	2	
7	09136-05057	SCREW, rear lower	2	
8	09180M06166	SPACER	2	
9	09320M07014	CUSHION, rear	2	
10	47311M47E10	COVER, center	1	
11	47115M05F00	CUSHION, pillion	2	
12	47131M47E10	COVER, frame lower RH	1	
13	47121M47E10	COVER, frame front RH	1	
14	47221M47E10	COVER, frame front LH	1	
15	03541-05123	SCREW, inner	8	
16	02142-06163	SCREW, upper	2	
17	09139-06083	SCREW, front side	2	
18	09148-05020	NUT, front center	1	
19	09136-06004	SCREW, front	2	

FIG. 35

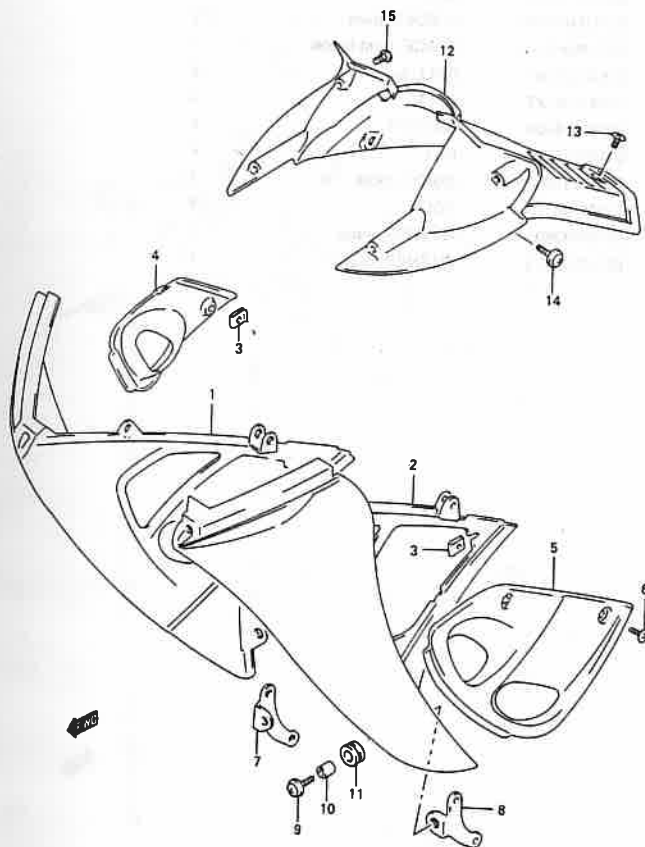
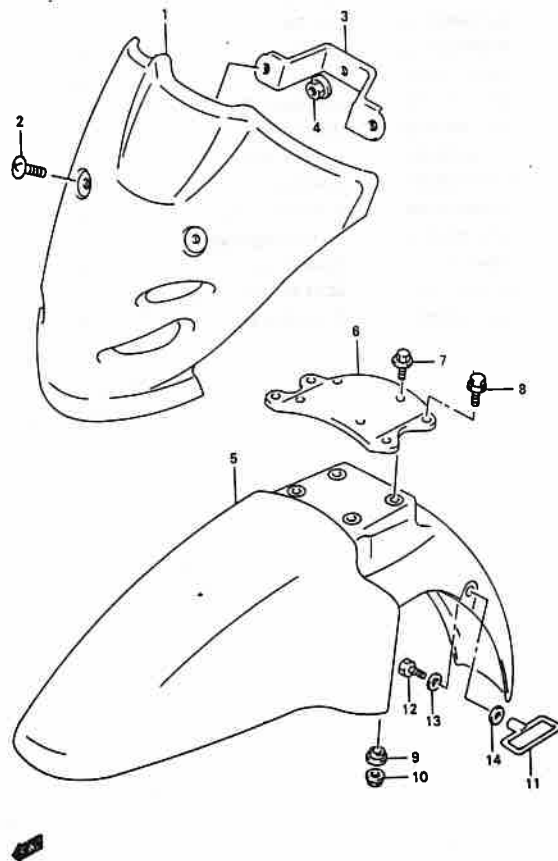


FIG. 35 (G-3) LEG SHIELD

REF. NO.	PART NO.	DESCRIPTION	Q'TY	REMARKS
1	48111M47E10	SHIELD, leg RH	1	
2	48121M47E10	SHIELD, leg LH	1	
3	09148-05020	NUT, lid	3	
4	48112M47E10	LID, RH	1	
5	48122M47E10	LID, LH	1	
6	03541-05163	SCREW, LID	3	
7	48160M47E10	BRACKET, RH	1	
8	48170M47E10	BRACKET, LH	1	
9	09136-06009	SCREW, lower	2	
10	09180M06263	SPACER	2	
11	09320M09026	CUSHION, lower	2	
12	48131M47E10	SHIELD, leg center	1	
13	03541-05163	SCREW, lower	1	
14	09136-06004	SCREW, side	2	
15	03541-04163	SCREW, upper	4	

4

FIG. 36



4

FIG. 36 (G-4) FRONT FENDER

REF. NO.	PART NO.	DESCRIPTION	QTY	REMARKS
1	51871M47E10	COVER, steering	1	
2	02142-06103	SCREW	2	
3	51860M47E10	PLATE, steering cover	1	
4	08316-10063	NUT	1	
5	53111M47E10	FENDER, front	1	
6	53114M47E10	BRACE, front fender	1	
7	01547-05167	BOLT, brace	4	
8	01547-06127	BOLT	4	
9	09169-05009	WASHER	4	
10	09159-05026	NUT	4	
11	58620-35500	GUIDE, cable	1	
12	01500-06123	BOLT	1	
13	09169M06034A	WASHER, inner	1	
14	09160-06079	WASHER, outer	1	

FIG. 37

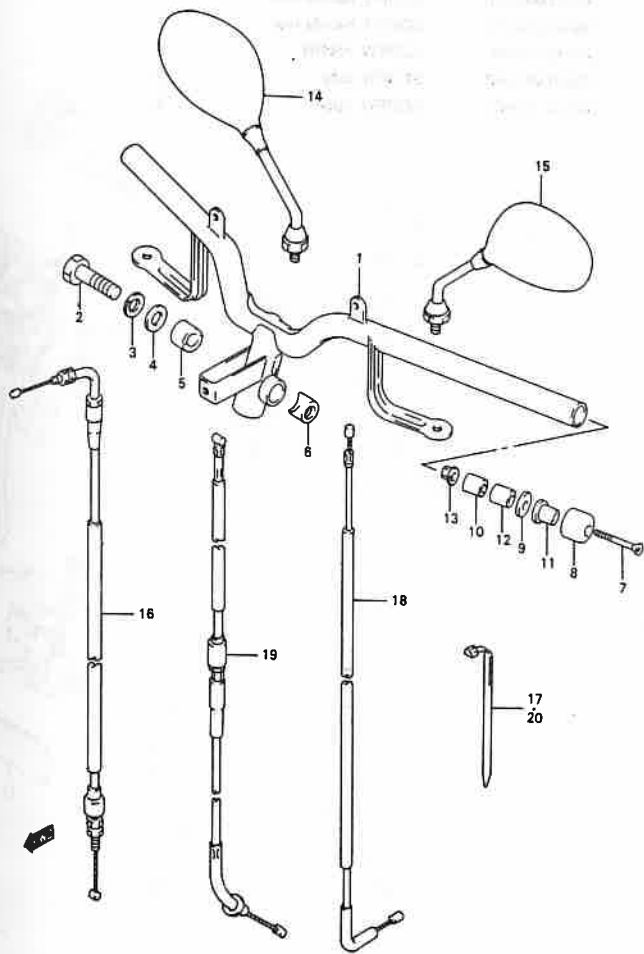


FIG. 37 (G-5) HANDLEBAR

REF. NO.	PART NO.	DESCRIPTION	QTY	REMARKS
1	56110M47E10	HANDLEBAR	1	
2	09100-12061	BOLT	1	
3	08321-01123	LOCK WASHER	1	
4	08322-01123	WASHER	1	
5	51358-35420	STOPPER, RH	1	
6	51359-35410	STOPPER, LH	1	
7	09127-06018	SCREW	2	
8	56278M47E00	BALANCER, handlebar	2	
9	09160-06126	WASHER, balancer	2	
10	56276-17D00	SPACER, expander	2	
11	56272M47E10	EXPANDER, balancer	2	
12	56272M31C00	EXPANDER, inner	2	
13	08316-10063	NUT	2	
14	56500M31CC0	MIRROR ASSY, rear view RH	1	
15	56600M31CC0	MIRROR ASSY, rear view LH	1	
16	58300M47E10	CABLE ASSY, throttle	1	
17	09407-19401	CLAMP	1	
18	58410M47E10	CABLE, starter	1	
19	58200M47E10	CABLE ASSY, clutch	1	
20	09407-25401	CLAMP	1	

FIG. 38

FIG. 38 (G-6) HANDLE COVER

38-00
24-00

REF. NO.	PART NO.	DESCRIPTION	QTY	REMARKS
1	56311M47E10	COVER, handle front	1	
2	56321M47E10	COVER, handle rear	1	
3	02142-05123	SCREW, FR/RR	2	
4	03511M04163	SCREW, side	2	
5	03541-05163	SCREW, upper	2	

4

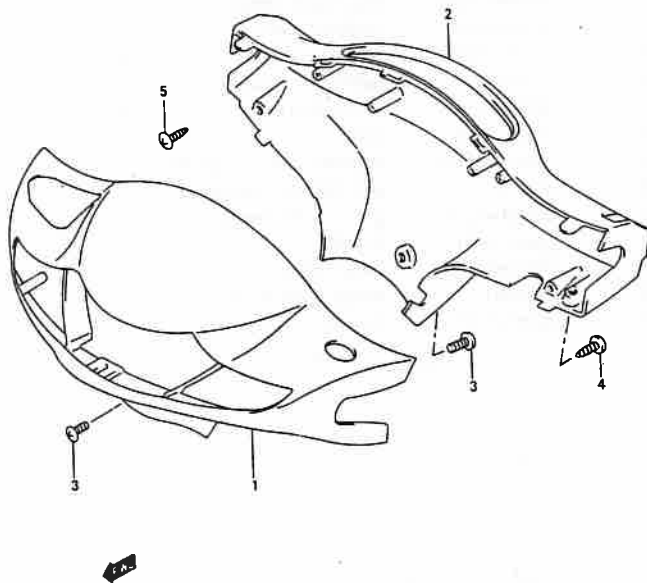
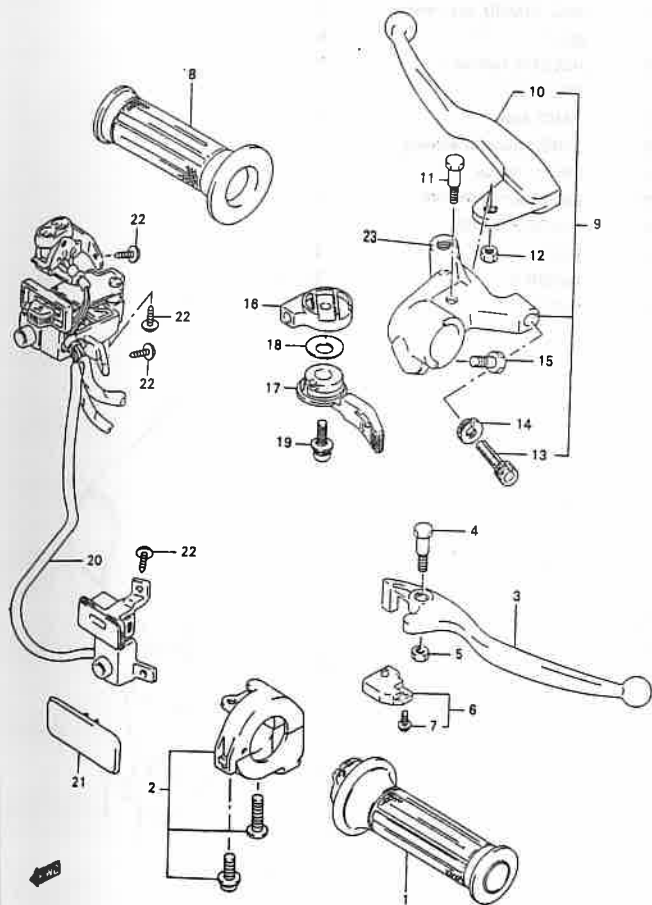


FIG. 39

FIG. 39 (G-7) HANDLE LEVER



REF. NO.	PART NO.	DESCRIPTION	Q'TY	REMARKS
1	57110M47E10	GRIP, throttle	1	
2	57100M47E10	CASE ASSY, throttle	1	
3	57421M21D00	LEVER, brake	1	
4	57431-21D00	BOLT	1	
5	08319-21063	NUT	1	
6	57460-17C00	SWITCH ASSY, stop	1	
7	57465-17C00	.SCREW	1	
8	57211M47E10	GRIP, LH	1	
9	57500M47E10	LEVER ASSY, clutch	1	
10	57621M21D10	.LEVER, clutch	1	
11	57431M14A00	.BOLT	1	
12	08319M21065	.NUT	1	
13	57441-11010	.ADJUSTER	1	
14	57442-11010	.NUT	1	
15	01547-06203	.BOLT	1	
16	37572-49441	BODY, starter	1	
17	58721-27503	LEVER	1	
18	58722-03011	WASHER	1	
19	02112-75203	SCREW	1	
20	37200-47E20	SWITCH ASSY, handle RH	1	
21	37251-20E00	CAP	1	
22	03541-04123	SCREW	5	
23	57511M47E10	HOLDER LEVER CLUTCH	1	

4

FIG. 40

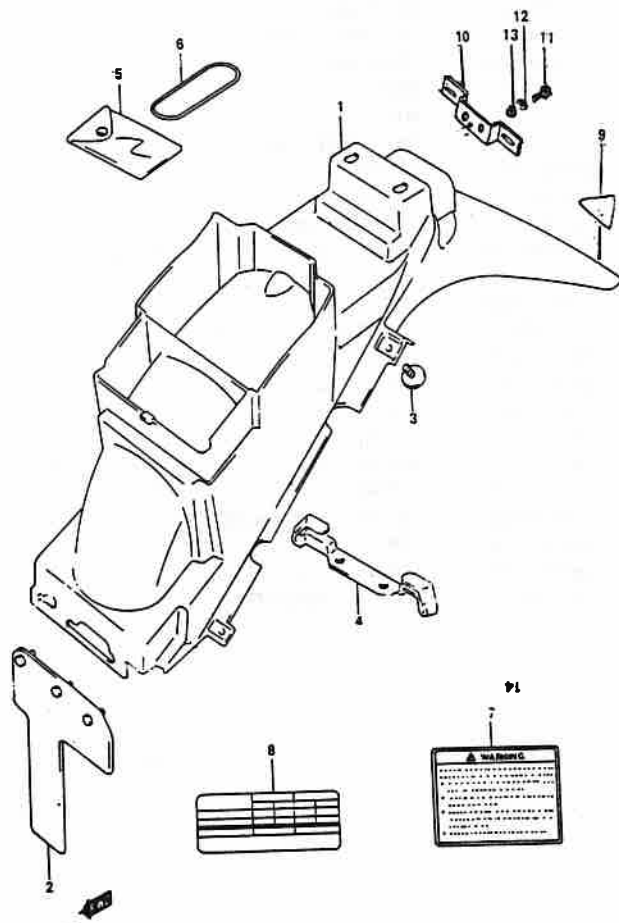


FIG. 40 (G-8) REAR FENDER

REF. NO.	PART NO.	DESCRIPTION	Q'TY	REMARKS
1	63111M47E10	FENDER, rear	1	
2	63411M47E10	MUD GUARD, rear fender	1	
3	09116-06168	BOLT	6	
4	95721M47E00	HOLDER, helmet	1	
5	09800-21007	TOOL SET	1	
6	33651M12910	BAND, tool	1	
7	68319M33E00	LABEL, general warning	1	
8	68332M47E10	LABEL, tire air	1	
9	35970M21D00	EMBLEM, tri reflective	1	
10	35927M36510	PLATE LICENSE	1	
11	02142-06163	BOLT	2	
12	09160-06126	WASHER	2	
13	08316-10063	NUT	2	

4

FIG. 41

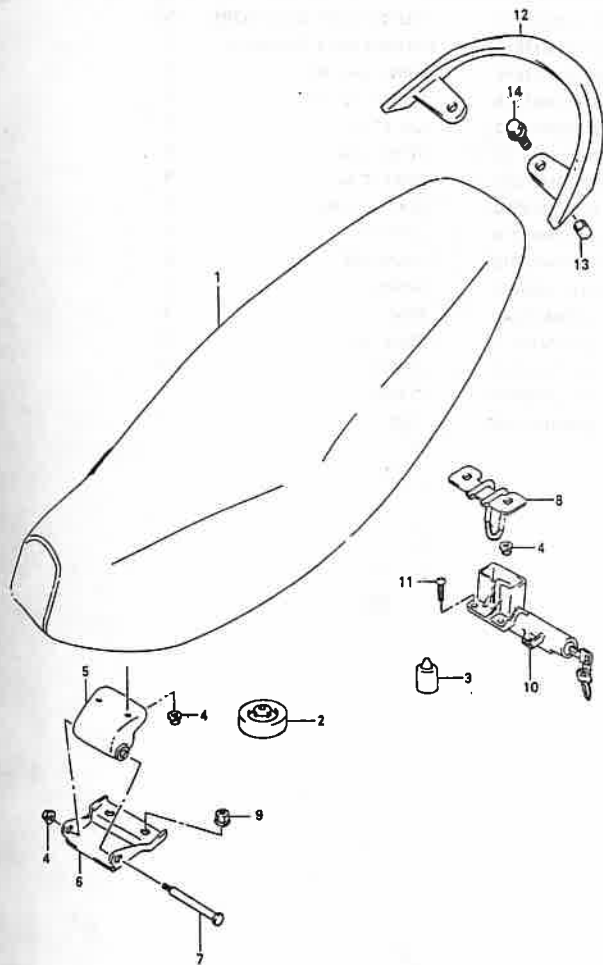


FIG. 41 (G-9) SEAT

REF. NO.	PART NO.	DESCRIPTION	QTY	REMARKS
1	45100M47E10	SEAT ASSY	1	
2	09321M14005	.CUSHION	2	
3	45149M35410	.CUSHION	2	
4	08316-20063	.NUT	5	
5	45210M21D10	.BRACKET, seat support, front	1	
6	45281M21D00	.BRACKET, seat support, lower	1	
7	09111-06001	.BOLT (6x71.5)	1	
8	45210M21D00	.STRIKER, seat lock	1	
9	08316-20063	NUT	2	
10	45700-47E00	LOCK SET, seat	1	
11	02112-06203	SCREW	2	
12	46211M47E10	HANDLE, pillion rider	1	
13	46212M47E00	SPACER, handle	2	
14	01810-08303	BOLT	2	

4

FIG. 42

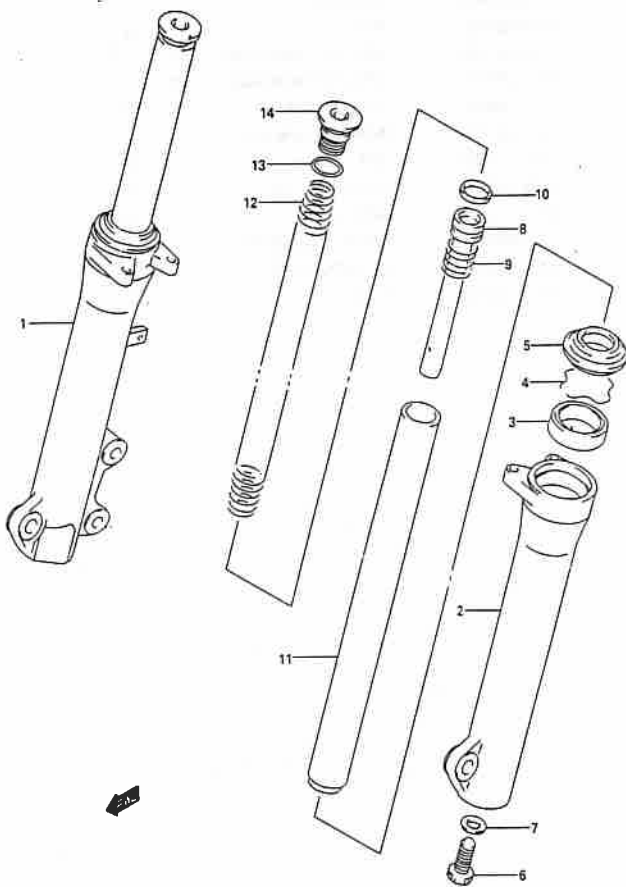


FIG. 42 (H-2) FRONT DAMPER

REF. NO.	PART NO.	DESCRIPTION	QTY	REMARKS
	51103M47E10	DAMPER ASSY, front fork RH	1	
	51104M47E10	DAMPER ASSY, front fork LH	1	
1	51130M47E10	.TUBE, outer RH	1	
2	51140M47E10	.TUBE, outer LH	1	
3	51153M39140	..OIL SEAL	2	
4	51156M39140	..RING, snap	2	
5	51173M21D00	..DUST SEAL	2	
6	51147M16510	..BOLT, cylinder	2	
7	51148M41310	..GASKET	2	
8	51146M47E10	..CYLINDER	2	
9	51177M35400	..SPRING	2	
10	51196M39140	..RING	2	
11	51110M47E10	..TUBE, inner	2	
12	51171M47E10	..SPRING	2	
13	51181M37B00	..O RING	2	
14	51351M47E10	..CAP	2	

4

FIG. 43

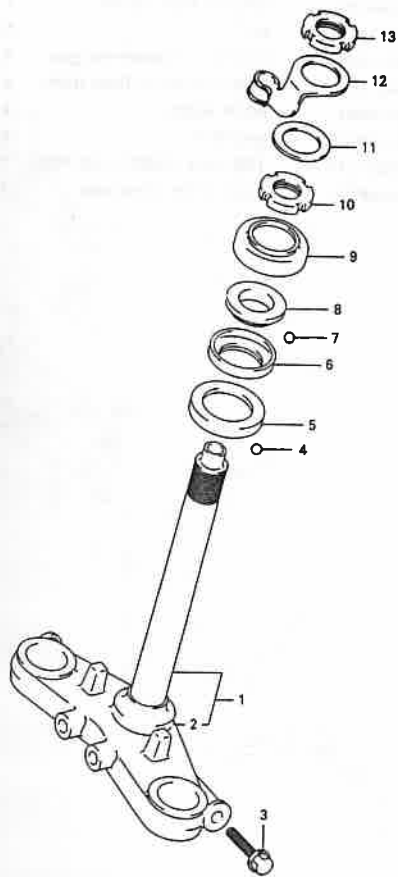


FIG. 43 (H-3) STEERING STEM

REF. NO.	PART NO.	DESCRIPTION	QTY	REMARKS
1	51410-47E10	STEM, steering	1	
2	51622-35400	RACE	1	
3	01570-08353	BOLT, stem	4	
4	06111-06003	BALL, lower	27	
5	51612-35400	RACE, inner lower	1	
6	51611-20002	RACE, inner upper	1	
7	06111-06003	BALL, upper	22	
8	51621-25000	RACE, outer upper	1	
9	51643M06001	SEAL, dust upper	1	
10	51631-05000	NUT, stem	1	
11	09166-24001	WASHER	1	
12	59251M21D10	CLAMP, brake hose	1	
13	51631-05000	NUT, stem	1	

FIG. 44

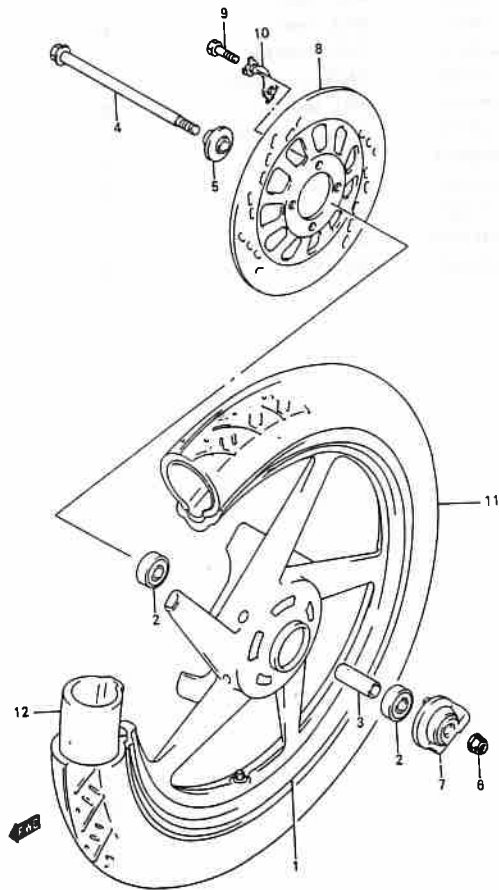


FIG. 44 (H-4) FRONT WHEEL

REF. NO.	PART NO.	DESCRIPTION	Q'TY	REMARKS
1	54111M47E00	WHEEL, front (1.40x17)	1	
2	08123M63007	BEARING	2	
3	09180M10148	SPACER, front hub (10.2x16x51)	1	
4	54711-04701	AXLE, front	1	
5	54750-46100	SPACER, front axle RH	1	
6	08319-31107	NUT	1	
7	54600-21D00	BOX ASSY, speedometer gear	1	
8	59211-21D70	DISC, front brake (Gold) (NHK)	1	
9	09100-08094	BOLT (8x30)	4	
10	09169M08019	WASHER	2	
11	55110M47E10	TIRE, front (70/90-17 38P IRC)	1	
12	55200M01011	TUBE ASSY, wheel inner	1	

FIG. 45

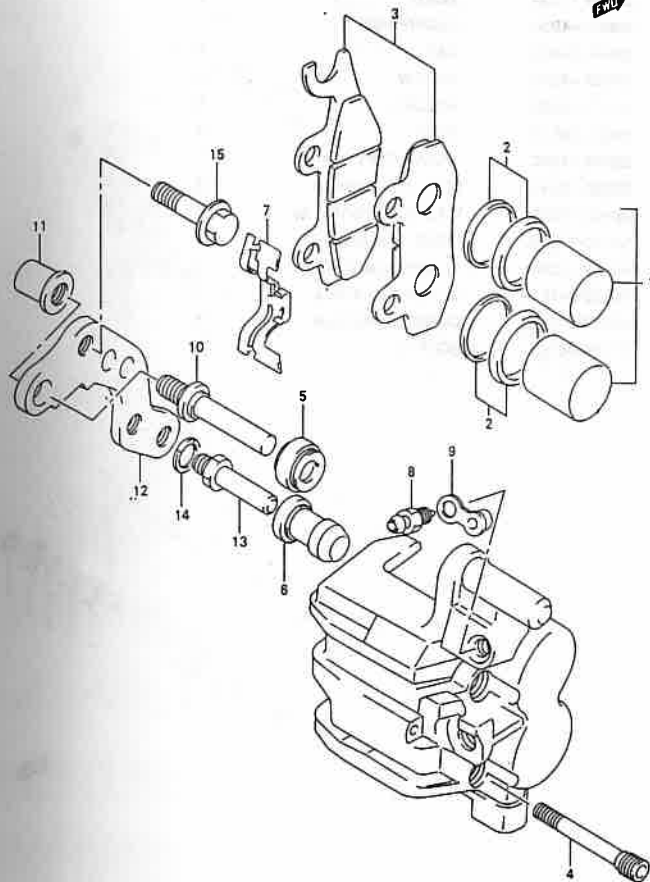
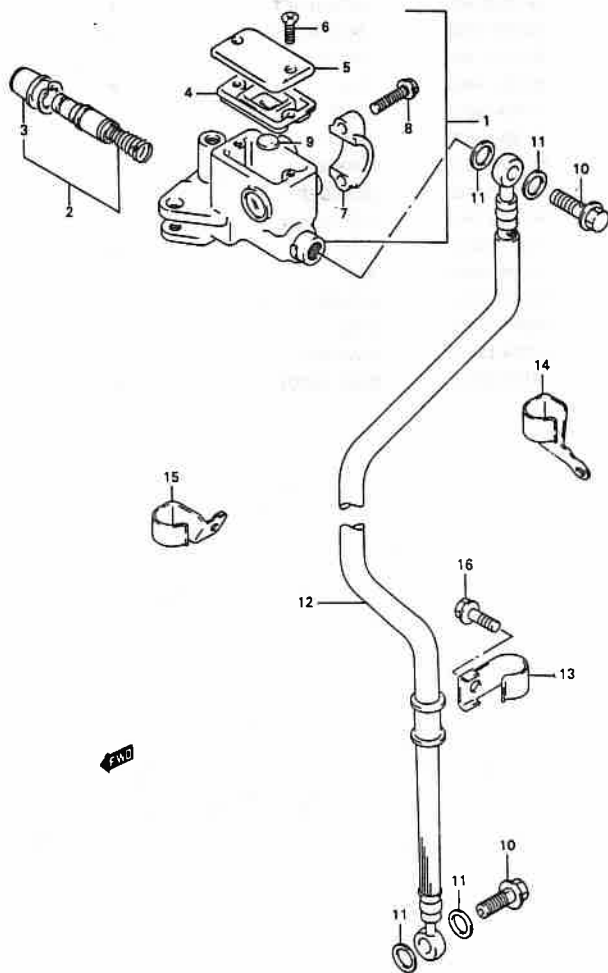


FIG. 45 (H-5) FRONT CALIPER

REF. NO.	PART NO.	DESCRIPTION	QTY	REMARKS
	59100-47E10	CALIPERS ASSY, front	1	
1	69100-31810	.PISTON SET	1	
2	59300-13820	..SEAL SET, piston	1	
3	59100-21850	.PAD SET	1	
4	59345-14600	.PIN	2	
5	59303-14500	.BOOT	1	
6	59386-13A00	.BOOT	1	
7	69115-31D10	.SPRING	1	
8	59121-01A00	.BLEEDER	1	
9	59122-01A00	.CAP, bleeder	1	
10	59387-00B20	.PIN	1	
11	59388-00B20	.NUT	1	
12	59151-47E00	.BRACKET	1	
13	59382-13A00	.BOLT	1	
14	59314-13A00	.WASHER	1	
15	09103-08107	BOLT (8x33)	2	

FIG. 46



4

FIG. 46 (H-6) FRONT MASTER CYLINDER

REF. NO.	PART NO.	DESCRIPTION	Q'TY	REMARKS
1	59600-47E10	CYLINDER ASSY, front master	1	
2	59600-21810	.PISTON & CUP SET	1	
3	59666-44300	..BOOT	1	
4	59667-44B00	.DIAPHRAGM	1	
5	59669-24A00	.CAP	1	
6	69689-49300	.SCREW	2	
7	59671-29C00	.HOLDER	1	
8	59675-06F10	.BOLT	2	
9	59748-14500	.SEPARATOR	1	
10	09360-10042	BOLT (10x1.25x22)	2	
11	09161-10009	WASHER (10x15x1.5)	4	
12	59480-47E10	HOSE, front brake	1	
13	59268-19D50	CLAMP, hose lower	1	
14	59252M47E10	CLAMP, brake hose	1	
15	59256M47E10	CLAMP, brake hose	1	
16	01550-06103	BOLT	3	

FIG. 47

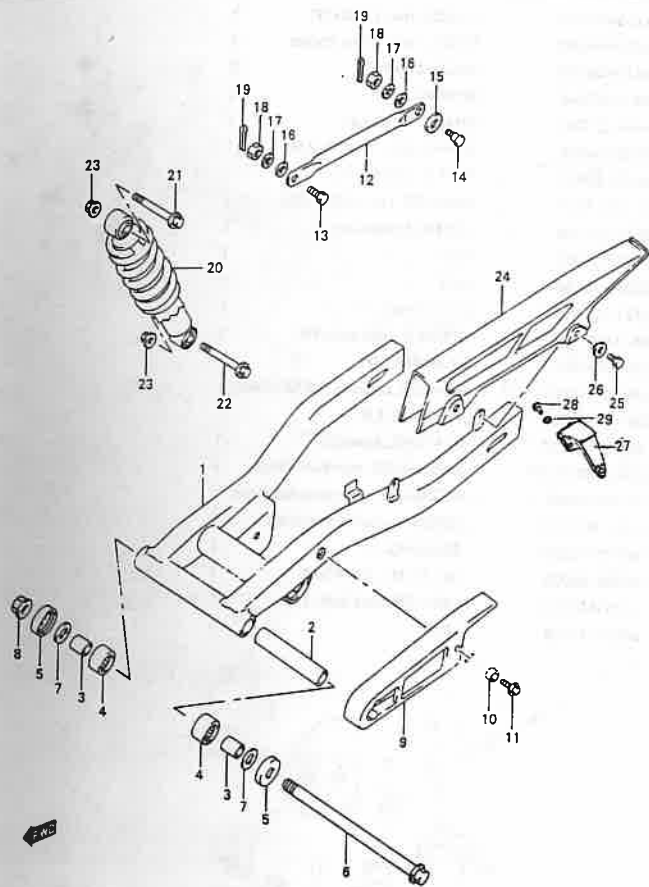


FIG. 47 (H-7) REAR SWINGING ARM

REF. NO.	PART NO.	DESCRIPTION	Q'TY	REMARKS
1	61100M47E10	SWINGING ARM, rear	1	
2	61282M21D01	SPACER, center	1	
3	61251-21D01	SPACER, pivot	2	
4	09263-17011	BEARING (17x24x20)	2	
5	61262-21D00	DUST SEAL	2	
6	61211-21D00	SHAFT, rear swinging arm	1	
7	08211-12281	WASHER	2	
8	08319-31128	NUT	1	
9	61273M21D00	BUFFER, chain touch defense	1	
10	09180-06255	SPACER (6.5x9x3.80)	1	
11	09116-06111	BOLT (6x20)	1	
12	64311M47E00	TORQUE LINK, rear brake	1	
13	09111-08015	BOLT, front (8x22)	1	
14	09111-08016	BOLT, rear (8x29)	1	
15	64322M09401	CUSHION, rear	1	
16	08322-01083	WASHER	2	
17	09162-08008	LOCK WASHER	2	
18	09140-08008	NUT	2	
19	04111-20208	COTTER PIN	2	
20	62100M47E10	ABSORBER ASSY, rear shock	1	
21	09103-10213	BOLT, upper (10x52)	1	
22	09103-10083	BOLT, lower (10x85)	1	
23	08319-31103	NUT	2	
24	61311M21D00	CASE, chain	1	
25	01517M09105	BOLT (6x8)	2	
26	09169-06041	WASHER	2	
27	61311M21D99A	REINFORCEMENT, chain case	1	
28	09229M21D99A	RIVET, reinf. chain case	1	
29	08322M01038	WASHER	1	

4

FIG. 48

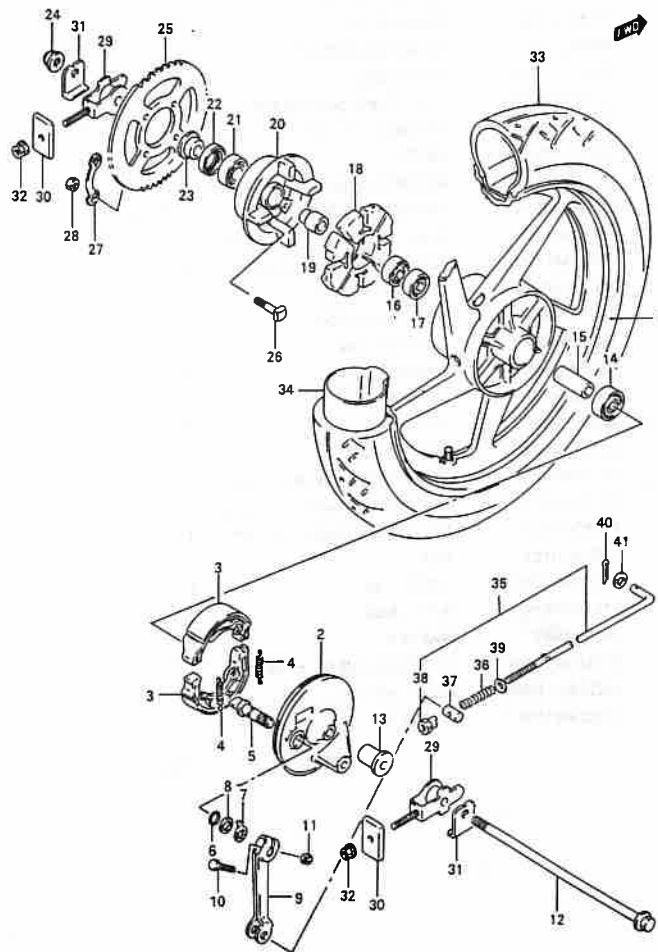


FIG. 48 (H-8) REAR WHEEL

REF. NO.	PART NO.	DESCRIPTION	Q'TY	REMARKS
1	64150M47E00	WHEEL, rear (1.60x17)	1	
2	64210M46003	PANEL, rear brake anchor	1	
3	54410M35060	SHOE, brake	2	
4	09443-07044	SPRING	2	
5	64441-21D00	SHAFT, brake cam	1	
6	09280-14003	O RING (ID: 13.8, D: 2.50)	1	
7	54492-35400	PLATE, brake lining	1	
8	09160-14054	WASHER (14.5x22x1.00)	2	
9	64451-21D01	LEVER, brake cam	1	
10	01500-06353	BOLT	1	
11	08316-10063	NUT	1	
12	64711-21D00	AXLE, rear	1	
13	64731M21D00	SPACER, rear axle, RH	1	
14	08143M63017	BEARING, RH	1	
15	09180M12143	SPACER, bearing (12.5X19X48)	1	
16	08143M62017	BEARING, LH	1	
17	08113M62017	BEARING, inner LH	1	
18	64651M30D00A	ABSORBER, rear hub shock	1	
19	64733-43000	RETAINER, rear sprocket drum	1	
20	64611M26500	DRUM, sprocket mounting	1	
21	08113M62037	BEARING	1	
22	09285-25003	OIL SEAL (25x40x6)	1	
23	64741M21D00	SPACER, rear axle, LH	1	
24	08319-31128	NUT	1	

FIG. 48

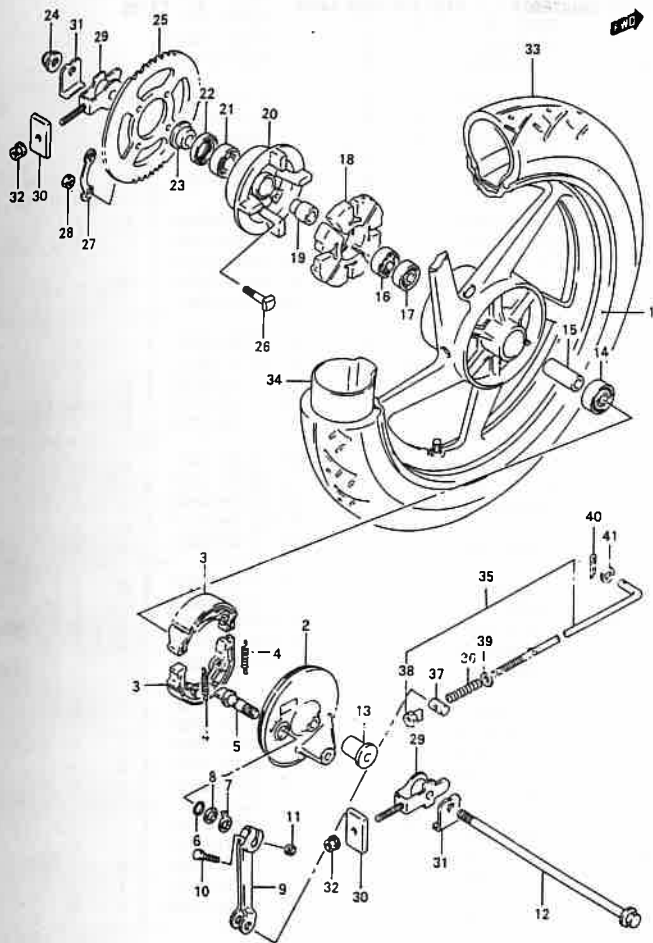


FIG. 48 (H-9) REAR WHEEL

REF. NO.	PART NO.	DESCRIPTION	Q'TY	REMARKS
25	64511-47E20	SPROCKET, rear (NT: 44)	1	
26	09105M08011	BOLT (8x36)	4	
27	09169M08011	LOCK WASHER	2	
28	08310-00083	NUT	4	
29	61410-21D00	ADJUSTER, chain	2	
30	61421M21D00	PLATE, chain adjuster guide	2	
31	64712M21D00	WASHER	2	
32	08319-31087	NUT	2	
33	65110M47E10	TIRE, rear (80/90-17 44P) IRC	1	
34	55200M03600	TUBE ASSY, wheel inner	1	
35	43300-47E00	ROD ASSY, rear brake	1	
36	09440-09035	.SPRING	1	
37	09209-11002	.PIN	1	
38	09150-06001	.NUT	1	
39	08322-01063	.WASHER, rear	1	
40	04111-20208	.COTTER PIN	1	
41	08322-01053	.WASHER, front	1	

4

FIG. 49

FIG. 49 GRAPHIC EMBLEM

REF. NO.	PART NO.	DESCRIPTION	Q'TY	REMARKS
1	68190M47E99A	EMBLEM, cover strg. head	1 (SUZUKI)	
2	68150M47E99A	EMBLEM, shield leg	2 125 DOHC	
3	68130M47E99A	EMBLEM, cover frame	2 FX125	



4

NO.

000

DM47E
5-33D
1-47E
IM47E
3-35C

3-17E
DM47E
IM35E
D-47E
DM05E

DM05E
DM05E
DM47E
IM47E

IM47E
DM47E
IM47E
-450
M47E

M47E
Y-20E
IM20E
-30B
-35C

I-47E
-47E
I-47E
-47E
I-47E

-47E
I-053E
-30D
-47E
-47E

-47E
-47E
-47E
-16E
-44B

NO.	FIG. NO. REF. NO.	PART NO.	FIG. NO. REF. NO.	PART NO.	FIG. NO. REF. NO.
0000		12760-16E00	10 - 1	13268-47070	11 - 24
		12771-16E00	10 - 2	13279-45400	11 - 23
		12782-47E00	10 - 3	13291-29900	11 - 25
		12811-16E00	10 - 6	13295-29900	11 - 26
		12812-35C00	10 - 4	13370-47E00	11 - 9
0M47E00	2 - 1	12830-31312	10 - 7	13383-47E10	11 - 8
5-33D71	2 - 2	12837M31320	10 - 9	13385-05F00	11 - 13
1-47E00	2 - 7	12839-38200	10 - 8	13387-33E00	11 - 6
1M47E00	1 - 1	12891-16E00	9 - 7	13394-17E60	11 - 7
3-35C00	1 - 2	12892-05C00-120	9 - 15	13411-01400	11 - 19
8-17E00	1 - 3	12892-05C00-125	9 - 15	13417-01010	11 - 20
0M47E00-0F0	3 - 1	12892-05C00-130	9 - 15	13417-47E00	11 - 2
1M35C00	3 - 4	12892-05C00-135	9 - 15	13418-43410	11 - 21
0-47E00	2 - 23	12892-05C00-140	9 - 15	13500-47E00	11 - 3
0M05F10	4 - 1	12892-05C00-145	9 - 15	13502-47E00	11 - 1
0M05F10	4 - 1	12892-05C00-150	9 - 15	13507-04F00	11 - 4
0M05F10	4 - 1	12892-05C00-155	9 - 15	13581-47E00	11 - 5
0M47E00	5 - 1	12892-05C00-160	9 - 15	13601-05148	11 - 32
1M47E00	5 - 10	12892-05C00-165	9 - 15	13615-43010	11 - 29
1M47E00	5 - 19	12892-05C00-170	9 - 15	13681-04010	11 - 22
0M47E00	5 - 21	12892-05C00-175	9 - 15	13684-47E00	11 - 33
0M47E00	5 - 3	12892-05C00-180	9 - 15	13720M47E10	12 - 1
0M47E00	5 - 11	12892-05C00-185	9 - 15	13780-47E00	12 - 2
0-5010	5 - 2	12892-05C00-190	9 - 15	13824-00A00	12 - 9
0M47E00-0F0	6 - 22	12892-05C00-195	9 - 15	13832-11036	12 - 13
0M47E00-050	6 - 22	12892-05C00-200	9 - 15	13836-42A00	12 - 12
0-20E50	6 - 23	12892-05C00-205	9 - 15	13850-47E00	12 - 6
0M20E00-050	6 - 23	12892-05C00-210	9 - 15	13872-00A00-010	12 - 8
0-30B00	6 - 24	12892-05C00-215	9 - 15	13881M47E00	12 - 3
0-35C01-0B0	6 - 2	12892-05C00-220	9 - 15	14181M18C00	13 - 1
0-47E00	6 - 1	12911-16E00	9 - 8	14305M47E10	13 - 2
0-47E00	6 - 3	12912-16E00	9 - 9	14773M41D00	13 - 6
0-47E00	6 - 5	12921-47E00	9 - 10	14781M47E00	13 - 9
0-47E00	6 - 6	12931-16E00	9 - 11	16311-47E00	6 - 21
0-47831	7 - 5	12932-32C00	9 - 12	16321-05201	6 - 20
0-47E00	7 - 1	12933-16E00	9 - 13	16331-47E00	14 - 2
0-05300	7 - 7	13110-47E00	2 - 18	16400-47E10	14 - 1
0-30D00	7 - 4	13200-47E10	11	16460-47E00	15 - 5
0-47E00	8 - 1	13240-47E00	11 - 16	16470-47E00	15 - 6
0-47810	8 - 4	13246-43010	11 - 14	16510-05240	14 - 7
0-47E00	6 - 7	13247-13A00	11 - 27	16512-47E00	14 - 9
0-47E00	9 - 1	13251-47E00	11 - 34	16520-30A00	14 - 6
0-47E10	9 - 2	13254-20010	11 - 11	16600-41E00	15 - 1
0-16E00	9 - 3	13267-47E00	11 - 28		
0-14B00	9 - 4	13268-37420	11 - 30		

PART NO.	FIG. NO. REF. NO.	PART NO.	FIG. NO. REF. NO.	PART NO.	FIG. NO. REF. NO.
20000		25312-12C00	18 - 9	31361-32C10	20 - 12
		25350-26D01	18 - 12	31361-38300	20 - 11
		25355-26D21	18 - 13	31497-45000	21 - 3
		25356-12C00	18 - 14	31800-47E00	23 - 1
		25381-13E10	18 - 8	31861-47E00	23 - 2
21111-35C20	6 - 14	25411-21D01	18 - 3	32101-47E00	21 - 1
	16 - 1	25421-35403	18 - 4	32102-47E00	21 - 2
21112-35C00	6 - 15	25510-47E20	18 - 18	32371-30D00	21 - 5
	16 - 2	25512-13E11	18 - 19	32800-47E00	23 - 6
21114-35C00	6 - 16	25520-12C10	18 - 27	32900-47E00	23 - 8
	16 - 3	25525-20A10	18 - 30	32980M44A10	23 - 9
21200-35C30	16 - 4	25526-47000	18 - 27A	33410-03D00	23 - 10
21251-13E00	16 - 12		18 - 33A	33510-48B10	23 - 12
21411-05200	16 - 6	25600-47E00	18 - 32	33541-23E01	23 - 13
21441-13A01	16 - 9	25652M16500	18 - 33	33542-47E00	23 - 14
	16 - 9A	25671-01000	18 - 20	33610M40D50-DRY	22 - 1
21451-19A00	16 - 10	26211-47E10	19 - 1	33651M12910	40 - 6
21462-02B40	16 - 15	26221M30A00	19 - 3	33652M35400	22 - 2
21483-13A00	16 - 10A	26231-09410	19 - 2	33810M47E00	23 - 5
23165-48000	16 - 13	26232-09401	19 - 10	33820M47E10	22 - 4
	16 - 18	26233-09400	19 - 11	33860M47E00	28 - 5
23261-13A01	16 - 21	26241-47E00	19 - 5	34111-47E10	24 - 3
23271-03D10	16 - 23	26300M47E00	19 - 13	34112-47E10	24 - 4
23271M21D99C	16 - 24	26352M01000	19 - 14	34120-47E00	24 - 1
23271M21D98B	17 - 1	27510-41730	17 - 31	34147-21D30	24 - 11
24121-05220	17 - 10	27531-05200	17 - 32	34173-47E10	24 - 9
24130-05330	17 - 2	27600M36012-122	17 - 33	34176-47E10	24 - 14
24221-29B01	17 - 3			34320-47E00	24 - 2
24231-05203	17 - 5			34383-21D30	24 - 13
24251-05203	17 - 11			34810M47E00	32 - 3
24311-29B01	17 - 12			34825-02100	32 - 4
24321-29B20	17 - 13			34910M47E10	24 - 16
24322-47E00	17 - 15			34938M47E00	24 - 17
24331-05203	17 - 16			35100M47E10	25 - 1
24341-05203	17 - 17			35124M47E10	25 - 4
24351-05202	17 - 26				
	17 - 14	31100-47E00	20 - 1	35125M47E10	25 - 5
24359-05200	17 - 27	31130-32C20	20 - 4	35171M47310	25 - 6
24421-05300	17 - 7	31132-32C10	20 - 3	35601M47E00	26 - 1
24741-05200	17 - 7	31133-32C10	20 - 5	35602M47E00	26 - 2
24741-12B00	18 - 10	31135-32C10	20 - 7	35612M47E00	26 - 9
	6 - 12	31150-06C00	20 - 13	35613M47E00	26 - 4
24742-18A00	17 - 29	31156-38300	20 - 9	35615M47E00	26 - 3
24751-05210	18 - 1	31175-47E00	20 - 2	35632M47E00	26 - 10
25221-08300	18 - 2	31264-32C10	20 - 10	35652M47E10	27 - 2
25231-47E00	18 - 5	31281-20E00	20 - 8	35672M47E10	27 - 3
25310-47E00					

5

PART NO.	FIG. NO. REF. NO.	PART NO.	FIG. NO. REF. NO.	PART NO.	FIG. NO. REF. NO.
35710M47E10	27 - 1	43610M34A00	31 - 9	51156M39140	42 - 4
35712M47E10	27 - 4	43612M21D00	31 - 11	51173M21D00	42 - 5
35912M47E10	27 - 5	43631M34A01	31 - 12	51147M16510	42 - 6
35927M3550	40 - 10	43700M21D00	31 - 8	51148M41310	42 - 7
35970M05F00	27 - 14	43710M34A00	31 - 10	51146M47E10	42 - 8
35970M21D00	40 - 9	44110M47E10	32 - 1	51177M35400	42 - 9
36321-21D30	24 - 5	44210-24D10	32 - 2	51196M39140	42 - 10
36331-21D30	24 - 6	44281M29C00	32 - 6	51110M47E10	42 - 11
36341-21D30	24 - 7	44300-21D00	33 - 1	51171M47E10	42 - 12
36343-47E00	24 - 8	45100M47E10	41 - 1	51181M37B00	42 - 13
36610M47E20	28 - 1	45149M35410	41 - 3	51351M47E10	42 - 14
37100-30D20	28 - 6	45210M21D00	41 - 8	51358-35420	37 - 5
37146-03A00	28 - 13	45210M21D10	41 - 5	51359-35410	37 - 6
37146-03A10	28 - 13	45281M21D00	41 - 6	51410-47E10	43 - 1
37146-03A20	28 - 13	45700-47E00	41 - 10	51611-20002	43 - 6
37146-03A30	28 - 13	46211M47E10	41 - 12	51612-35400	43 - 5
37155M31C00	28 - 7	46212M47E00	41 - 13	51621-25000	43 - 8
37200-47E20	39 - 20	47111M47E10	34 - 1	51622-35400	43 - 2
37251-20E00	39 - 21	47115M05F00	34 - 11	51631-05000	43 - 10
37572-49441	39 - 16	47121M47E10	34 - 13		
37720-47E00	18 - 36	47131M47E10	34 - 12	51643M06001	43 - 9
37740-31D00	28 - 9	47211M47E10	34 - 2	51860M47E10	36 - 3
38500-16D22	28 - 11	47221M47E10	34 - 14	51871M47E10	36 - 1
38610-09410	26 - 8	47311M47E10	34 - 10	53111M47E10	36 - 5
		48111M47E10	35 - 1	53114M47E10	36 - 6
40000		48112M47E10	35 - 4	54111M47E00	44 - 1
41100M47E10	29 - 1	48121M47E10	35 - 2	54410M35060	48 - 3
41541M47E00	29 - 2	48122M47E10	35 - 5	54492-35400	48 - 7
42100M47E00	30 - 1	48131M47E10	35 - 12	54600-21D00	44 - 7
42129-21D00	30 - 3	48160M47E10	35 - 7	54711-04701	44 - 4
42211M03001	30 - 2				
42251M03004	30 - 8				
42310M47E00	30 - 9				
43110M47E00	30 - 13	50000		56272M31C00	37 - 12
43120M47E00	30 - 14			56272M47E10	37 - 11
43300-47E00	48 - 35			56276-17D00	37 - 10
				56278M47E00	37 - 8
				56311M47E10	38 - 1
43510M47E00	31 - 1	51103M47E10	42	56321M47E10	38 - 2
43520M47E00	31 - 2	51104M47E10	42	56500M31CC0	37 - 14
43540M47E00	31 - 4	51130M47E10	42 - 1	56600M31CC0	37 - 15
43551M39110	31 - 3	51140M47E10	42 - 2	57100M47E10	39 - 2
43600M21D00	31 - 7	51153M39140	42 - 3	57110M47E10	39 - 1

PART NO.	FIG. NO. REF. NO.	PART NO.	FIG. NO. REF. NO.	PART NO.	FIG. NO.
57211M47E10	39 - 8				
57421M21D00	39 - 3	60000			
57431M14A00	39 - 11			90000	
57431-21D00	39 - 4				
57441-11010	39 - 13				
57442-11010	39 - 14	61100M47E10	47 - 1	95721M47E00	
57460-17C00	39 - 6	61211-21D00	47 - 6		
57465-17C00	39 - 7	61251-21D01	47 - 3		
57500M47E10	39 - 9	61262-21D00	47 - 5		
57511M47E10	39 - 23	61273M21D00	47 - 9		
57621M21D10	39 - 10	61282-21D01	47 - 2		
58200M47E10	37 - 19	61311M21D00	47 - 24		
58300M47E10	37 - 16	61311M21D99A	47 - 27		
58410M47E10	37 - 18	61410-21D00	48 - 29		
58620-35500	36 - 11	61421M21D00	48 - 30	00000	
58721-27503	39 - 17	62100M47E10	47 - 20	01421-06253	
58722-03011	39 - 18	63111M47E10	40 - 1		
59100-21850	45 - 3	63411M47E10	40 - 2	01500-06103	
59100-47E10	45	64150M47E00	48 - 1	01500-06123	
59121-01A00	45 - 8	64210M46003	48 - 2		
59122-01A00	45 - 9	64311M47E00	47 - 12	01500-06163	
59151-47E00	45 - 12	64322M09401	47 - 15		
59211-21D70	44 - 8	64441-21D00	48 - 5	01500-06203	
59251M21D10	43 - 12	64451-21D01	48 - 9	01500-06353	
59252M47E10	46 - 14	64511-47E20	48 - 25	01500-08253	
59256M47E10	46 - 15	64611M26500	48 - 20	01514M06105	
59268-19D50	46 - 13	64651M30D00A	48 - 18	01514M06125	
59300-13820	45 - 2	64711-21D00	48 - 12	01517M09105	
59303-14500	45 - 5	64712M21D00	48 - 31	01547-05167	
59314-13A00	45 - 14	64731M21D00	48 - 13	01547-06127	
59345-14600	45 - 4	64733-43000	48 - 19	01547-06163	
59382-13A00	45 - 13	64741M21D00	48 - 23	01547M06203	
59386-13A00	45 - 6	65110M47E10	48 - 33	01547-06253	
59387-00B20	45 - 10	68190M47E99A	49 - 1		
59388-00B20	45 - 11	68150M47E99A	49 - 2	01547-06303	
59480-47E10	46 - 12	68130M47E99A	49 - 3	01547-06353	
59600-21810	46 - 2	68319M33E00	40 - 7	01547-06403	
59600-47E10	46 - 1	68332M47E10	40 - 8	01547-06407	
59666-44300	46 - 3	69100-31810	45 - 1	01547-06503	
59667-44B00	46 - 4	69115-31D10	45 - 7	01547-06653	
59669-24A00	46 - 5	69689-49300	46 - 6	01547-06703	
59671-29C00	46 - 7			01550-06103	
59675-06F10	46 - 8			01550-06123	
59748-14500	46 - 9				

FIG. NO.	REF. NO.	FIG. NO. REF. NO.	PART NO.	FIG. NO. REF. NO.	PART NO.	FIG. NO. REF. NO.
50-06163	28 - 8 32 - 7		04111-20208	24 - 12 47 - 19 48 - 40	08316-20063	41 - 4 41 - 9 39 - 5
50-06253	27 - 13		04111-25158	31 - 14	08319M21065	39 - 12
50-08203	31 - 5		04211-09149	5 - 4	08319-21108	30 - 4
10-08303	41 - 14					
00						
450-10163	8 - 6			5 - 16	08319-31083	13 - 8
70-08353	13 - 4 43 - 3		04211-11129 04211-11169	3 - 5 2 - 8	08319-31087 08319-31103	48 - 32 31 - 6
12-04083	11 - 10 11 - 35		04211-13189 04221-04089	4 - 2 18 - 6	08319-31107	47 - 23 4 - 17
12-05087	11 - 31		04221-08129	6 - 8		44 - 6
12-05103	21 - 4 21 - 8		06111-06003	43 - 4 43 - 7	08319-31128	47 - 8 48 - 24
12-05163	18 - 37		07130-06123	7 - 10	08321M01063	13 - 11
06103	21 - 9		07130-06163	15 - 10	08321-01123	37 - 3
53						
2-06123	6 - 13 17 - 8		07130-06203 07130-08253	10 - 10 13 - 3	08322M01038 08322-01053	47 - 29 48 - 41
03	18 - 11		08113M62017	48 - 17	08322-01063	48 - 39
123	23 - 7		08113-62027	17 - 23	08322-01083	47 - 16
2-06163	2 - 20		08113M62037	48 - 21	08322-01123	37 - 4
163						
2-06203	23 - 11 21 - 6		08113-69050 08123-60027	18 - 7 17 - 9	08331-31146 08332-11063	18 - 26 14 - 4
203	41 - 11		08123M63007	44 - 2	08341-31039	21 - 11
353	20 - 6		08143M62017	48 - 16	09100-06153	30 - 16
253	32 - 5		08143M63017	48 - 14	09100-08094	44 - 9
6105						
2-06123	39 - 19		08211-06141	18 - 15	09100-12061	37 - 2
6125	17 - 28		08211-06181	10 - 5	09103-06108	2 - 6
9105	14 - 5			18 - 16		2 - 12
1167	12 - 10		08211-10285	8 - 5	09103-06132	2 - 5
1127	38 - 3		08211-12281	47 - 7	09103-08107	45 - 15
1163						
16203	13 - 10		08211-14321	19 - 8	09103-08289	2 - 22
3253	36 - 2		08211-15251	17 - 21	09103-08305	2 - 13
2-06123	12 - 11		08211-20352	16 - 5	09103-10052	4 - 15
2-06163	34 - 16		08310-00063	30 - 17	09103-10083	47 - 22
	40 - 11		08310-00067	18 - 29	09103-10148	4 - 16
3303						
M04163	27 - 8		08310-00083	48 - 28	09103-10213	47 - 21
5353	38 - 4		08316-10053	27 - 15	09105M08011	48 - 26
5403	39 - 22		08316-10063	2 - 16	09106-07009	1 - 4
5407	26 - 6			3 - 3	09111-06001	41 - 7
6503	26 - 7			18 - 17	09111-06032	9 - 5
6653						
6703	35 - 15			36 - 4	09111-08015	47 - 13
6103	34 - 15			37 - 13	09111-08016	47 - 14
6123	35 - 6			40 - 13	09111-10014	30 - 11
	35 - 13			48 - 11	09116-05003	16 - 17
	38 - 5		08316-10123	21 - 10	09116-06111	47 - 11

PART NO.	FIG. NO. REF. NO.	PART NO.	FIG. NO. REF. NO.	PART NO.	FIG. NO. REF. NO.
09116-06143	15 - 2	09168-08021	2 - 14		17 - 6
09116-06168	40 - 3	09168-10012	2 - 24		17 - 25
09127-06018	37 - 7	09168-12002	4 - 6	09262-20137	8 - 2
09128-06013	23 - 4		4 - 9	09262-28035	6 - 9
09128-06035	33 - 4		4 - 11	09262-35038	6 - 10
09136-05051	25 - 3	09168-14002	5 - 9	09263-10002	16 - 14
09136-05057	34 - 7		5 - 18	09263-14027	18 - 22
09136-06004	34 - 19	09168-14011	15 - 7	09263-15023	17 - 19
	35 - 14	09169-05009	36 - 9	09263-17011	47 - 4
09136-06009	35 - 9	09169M06034A	36 - 13	09263-22031	7 - 6
09136-06105	34 - 4	09169-06041	47 - 26	09263-28032-0B0	6 - 4
09137-05004	20 - 16	09169M08011	48 - 27	09280-04004	4 - 13
09139-06083	34 - 17	09169M08019	44 - 10	09280-12008	15 - 9
09140-06025	18 - 31	09169-16003	16 - 7	09280-13004	14 - 10
09140-08008	47 - 18	09180M06247	34 - 8	09280-14003	48 - 6
09140-16005	16 - 8	09180M06248	27 - 11	09280-17003	5 - 7
09140-16017	17 - 34	09180-06255	47 - 10	09280-19005	17 - 36
09140-16019	6 - 17	09180M06263	35 - 10	09280-22008	5 - 15
09148-05004	27 - 9	09180-06310	15 - 3	09280-24003	20 - 15
09148-05020	34 - 18	09180M06166	34 - 8	09280-26007	18 - 38
	35 - 3	09180-06167	34 - 5	09280-35001	2 - 19
09150-06001	48 - 38	09180M10148	44 - 3	09280-54001	14 - 8
09159-05026	36 - 10	09180M12143	48 - 15	09282-12009	6 - 11
09159-10097	30 - 12	09180-13007	7 - 1	09283-14006	18 - 23
09160-06079	36 - 14	09180-24003	20 - 15	09283-27010	17 - 24
09160-06126	37 - 9	09181-14167	18 - 21	09285-10004	16 - 20
	40 - 12	09181-16223	19 - 9	09285-16003	19 - 7
09160-06131	27 - 10	09181-20167	17 - 22	09285-25003	48 - 22
09160-08032	13 - 5	09200-06057	31 - 13	09289-04002	9 - 14
09160-10005	30 - 5	09206-08001	2 - 4	09320M07014	34 - 9
09160-12086	16 - 19	09206-13003	7 - 3	09320M08018	34 - 3
09160-14054	48 - 8	09209-05011	18 - 39	09320M08048	27 - 12
09160-20056	16 - 11	09209-11002	48 - 37	09320M09026	35 - 11
09161-10009	46 - 11	09229M21099A	47 - 28	09320-10015	15 - 4
09161-11008	1 - 5	09247-12103	4 - 5	09320M10045	34 - 6
09161-18005	18 - 34		4 - 10	09320M12058	13 - 7
09162-08008	47 - 17	09247-12106	4 - 12	09321M10001	30 - 6
09164-18002	18 - 35	09247-14026	5 - 17	09321M14005	41 - 2
09166-16012	6 - 18	09248-14005	5 - 8	09352-40703-600	11 - 36
09166-24001	43 - 11	09259-20008	5 - 6	09352-50823-600	33 - 6
09167-20011	17 - 20	09259-26011	5 - 14	09355-50105-400	33 - 2
09167-20030	17 - 35	09261-02001	14 - 3	09360-10042	46 - 10
09168-06004	2 - 9	09261-05005	9 - 6	09360-10047	2 - 25
	4 - 8	09261-10003	7 - 8	09360-12006	15 - 8
09168-06026	33 - 5	09262-20019	8 - 3	09380-20009	17 - 4

PART NO.	FIG. NO. REF. NO.	PART NO.	FIG. NO. REF. NO.	PART NO.	FIG. NO. REF. NO.
09381-10004	17 - 18	09494-00907	11 - 15		
09381-15001	2 - 3	09800-21007	40 - 5		
09401-08401	6 - 25				
09401-09403	33 - 7				
	33 - 3				
09401-14301	12 - 7				
09402-46208	2 - 21				
09402-52208	12 - 5				
09402-52208	12 - 4				
09404-06429	21 - 7				
	28 - 2				
09407-14403	28 - 4				
09407-25401	37 - 20				
09407-18403	28 - 3				
09407-19401	37 - 17				
09407-25401	28 - 4				
09420-04008	8 - 7				
09421-04004	6 - 19				
09440-03004	7 - 9				
09440-04010	18 - 40				
09440-09035	48 - 36				
09440M13027	33 - 8				
09440-15036	16 - 16				
09440-17009	18 - 24				
09440-18002	14 - 11				
09440-30007	19 - 6				
09443-06075	28 - 10				
09443-07044	48 - 4				
09443M11033	30 - 15				
09443M14022	30 - 10				
09443M16007	30 - 7				
09444-20001	18 - 25				
09448-38004	19 - 4				
09462M00073	22 - 3				
09471-12100	24 - 10				
09471M12114	26 - 5				
	27 - 6				
09471M12119	27 - 7				
09471M12124	25 - 2				
09481-20102	23 - 3				
09482M00456	2 - 17				
09491-21019	11 - 12				
09492-15016	11 - 18				
09493-24012	4 - 14				
09493-29002	11 - 17				